

# High Efficiency, 3-Channel WLED Driver with Flash Function

## Feature

- $\pm 1\%$  current matching across voltage, temperature, and process
- $\pm 3\%$  current accuracy across voltage, temperature, and process
- High efficiency, up to 91%
- Up to 29.6mA/string in backlight mode and up to 79.9mA/string in flash mode
- I<sup>2</sup>C/PWM dual dimming control mode
- 11-bit I<sup>2</sup>C exponential or linear mapping with programmable transition ramp time
- Programmable current sink turn on/off ramp time
- Selectable boost converter switching frequency 1MHz or 500kHz with shift up and down option
- Programmable slew rate control minimize switching noise and improve EMI performance
- Five configurable OVP thresholds (17.5V, 24V, 31V, 38V, 41.5V)
- Four configurable current limit thresholds (900mA, 1800mA, 2700mA, 3400mA)
- Programmable flash current and timeout
- LED open/short detection
- WLCSP 1.64mm x 1.24mm-12B
- 7-bit slave address (A7~A1) is 0110110 binary(0x36H)

## Applications

Mobile phones and Tablet Backlighting

## General Description

AW99703 is a highly accurate, highly matching three-string LCD backlighting power solution. It is a highly integrated step-up DC-DC converter operating with a wide input voltage from 2.7V to 5.5V and a temperature range from -40°C to 85°C, accommodating 1-cell lithium ion battery or 5V supply.

The AW99703 integrates a high voltage MOSFET, and three high accuracy, high voltage current sinks. Each current sink can be regulated up to 29.6mA in backlight mode. In flash mode, flash current sink can be regulated up to 79.9mA, and flash timeout can be regulated up to 1.5sec.

The LED current is adjusted via an I<sup>2</sup>C interface or through a logic level PWM input. The PWM duty cycle is internally sensed and mapped to an 11-bit linear current.

Thorough protection features include LED fault (open and short) detection, cycle-by-cycle current-limit protection, output over-voltage protection and thermal shutdown.

## Typical Application Circuit

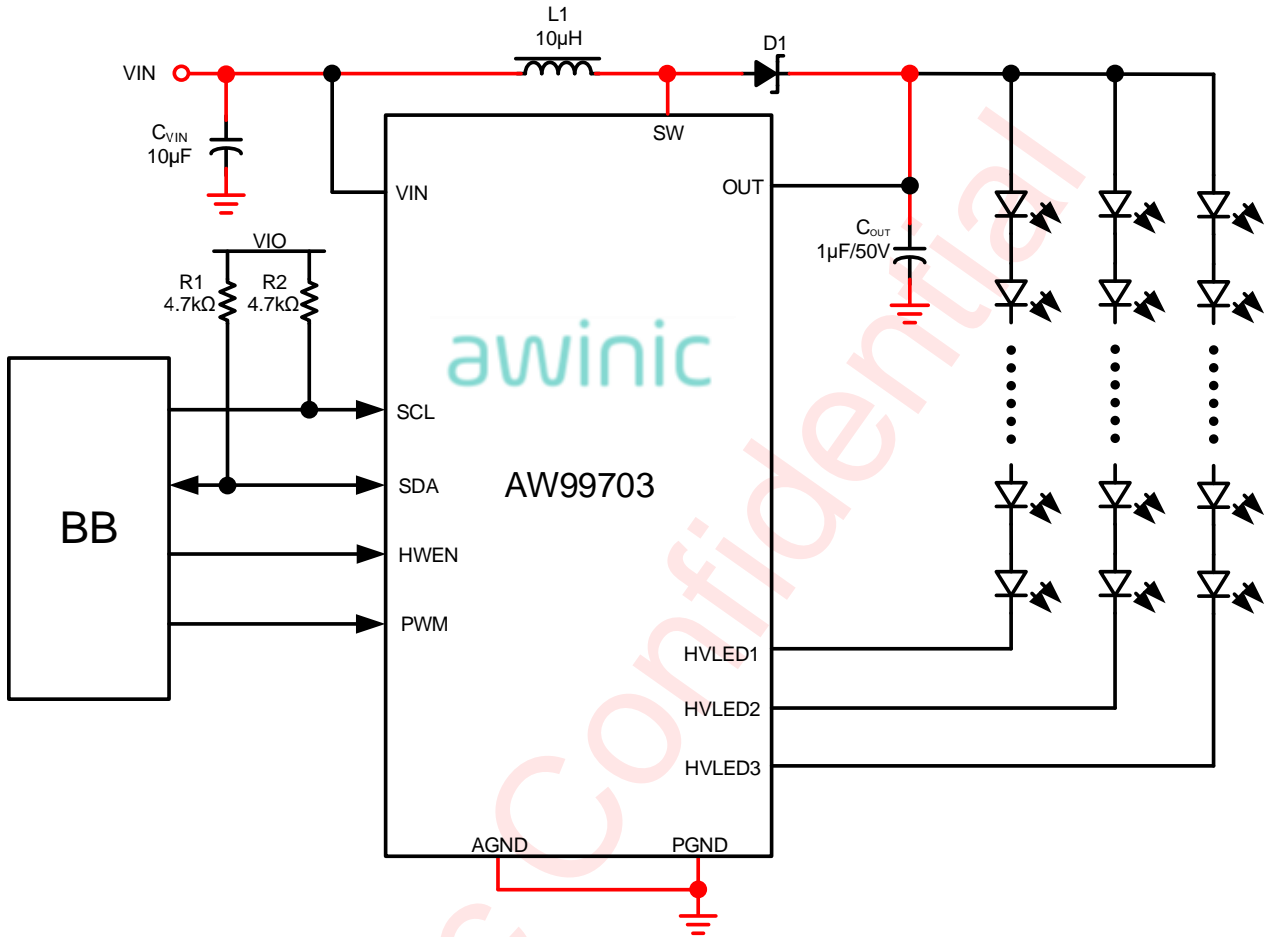
**Notice for typical application circuit:**

The power/ground path marked in red as shown in the figures above, please traces according power line alignment rules.

## Pin Configuration and Top Mark

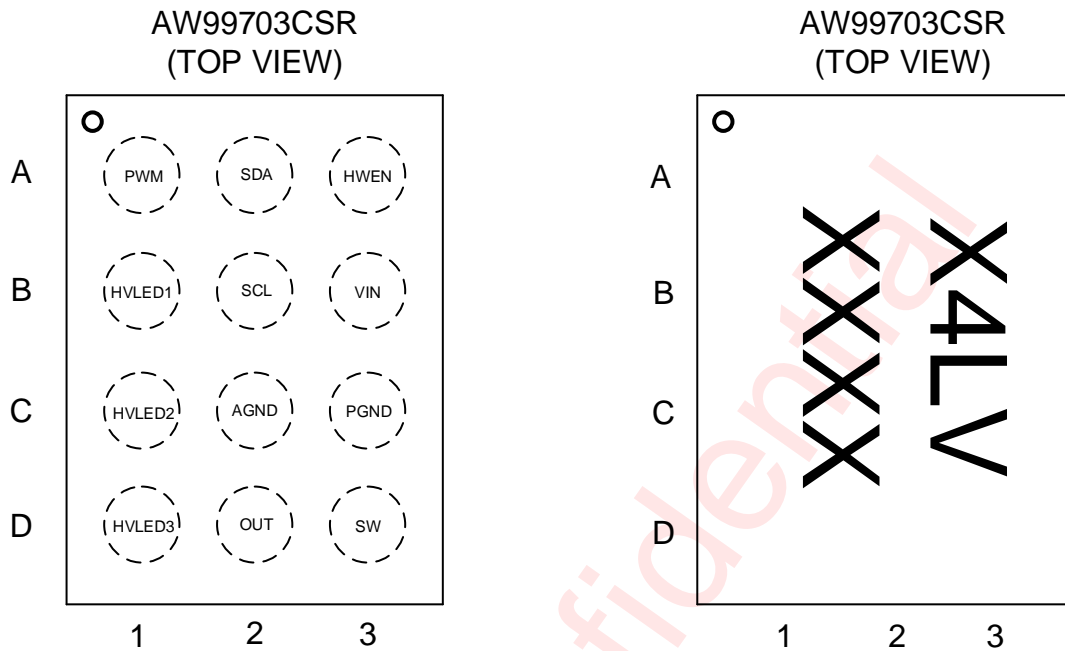

X4LV - AW99703CSR

XXXX - Production Tracing Code

## Pin Definition

PIN		TYPE	DESCRIPTION
NUMBER	NAME		
A1	PWM	Input	Input for PWM signal. With an internal 400kΩ pull-down resistor to GND.
A2	SDA	I/O	Serial data connection for I <sup>2</sup> C-Compatible interface.
A3	HWEN	Input	Input for Hardware enable. Logic high input to enable the device. With an internal 400kΩ pull-down resistor to GND.
B1	HVLED1	Input	Input pin to high-voltage current sink 1. The minimum voltage of HVLED1, HVLED2 and HVLED3 is chosen to compare with VHR.
B2	SCL	Input	Serial clock connection for I <sup>2</sup> C-compatible interface.
B3	VIN	Input	Power voltage with 2.7V to 5.5V range.
C1	HVLED2	Input	Input pin to high-voltage current sink 2. The minimum voltage of HVLED1, HVLED2 and HVLED3 is chosen to compare with VHR.
C2	AGND	GND	Analog ground.
C3	PGND	GND	Power ground.
D1	HVLED3	Input	Input pin to high-voltage current sink 3. The minimum voltage of HVLED1, HVLED2 and HVLED3 is chosen to compare with VHR.
D2	OUT	Input	Connect to the positive pin of the output capacitor. The voltage of OUT pin is sensed for OVP.
D3	SW	Output	Connect to the drain of the internal NFET. Connect SW to the junction of the inductor and the Schottky diode anode.

Functional Block Diagram

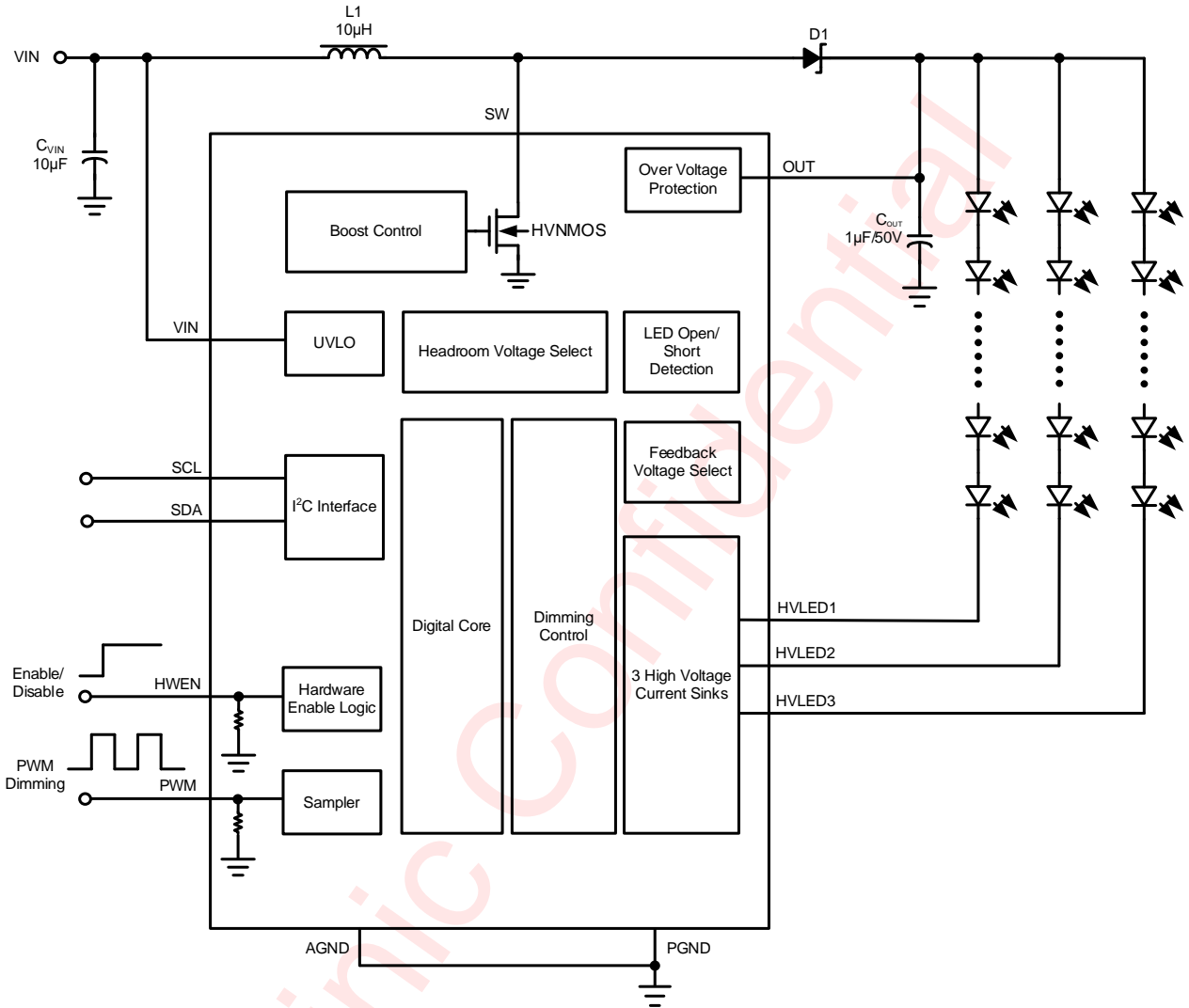

## Ordering Information

Part Number	Temperature	Package	Marking	Moisture Sensitivity Level	Environmental Information	Delivery Form
AW99703CSR	-40°C~85°C	WLCSP 1.64mmX1.24mm-12B	X4LV	MSL1	ROHS+HF	3000 units/ Tape and Reel

## Absolute Maximum Ratings<sup>(NOTE1)</sup>

PARAMETERS	RANGE
Supply voltage range VIN <sup>(NOTE 2)</sup>	-0.3V to 6V
Voltage on PWM, HWEN, SCL, SDA <sup>(NOTE 2)</sup>	-0.3V to 6V
Voltage on SW, OUT, HVLED1, HVLED2, HVLED3 <sup>(NOTE 2)</sup>	-0.3V to 43V
Junction-to-ambient thermal resistance $\theta_{JA}$	80°C/W
Operating free-air temperature range	-40°C to 85°C
Operating Junction temperature T <sub>J</sub>	-40°C to 150°C
Storage temperature T <sub>STG</sub>	-65°C to 150°C
Lead Temperature (Soldering 10 Seconds)	260°C
ESD <sup>(NOTE 3)</sup>	
ALL PINS HBM (human body model) <sup>(NOTE 4)</sup>	±2kV
ALL PINS CDM (charge device model) <sup>(NOTE 5)</sup>	±1.5kV
Latch-up <sup>(NOTE 6)</sup>	
Latch-up current maximum rating per JEDEC standard	+IT: 200mA -IT: -200mA

NOTE1: Conditions out of those ranges listed in "absolute maximum ratings" may cause permanent damages to the device. In spite of the limits above, functional operation conditions of the device should within the ranges listed in "recommended operating conditions". Exposure to absolute-maximum-rated conditions for prolonged periods may affect device reliability.

NOTE2: All voltage values are with respect to network ground terminal.

NOTE3: This integrated circuit can be damaged by ESD if you don't pay attention to ESD protection. AWINIC recommends that all integrated circuits be handled with appropriate precautions. Failure to observe proper handling and installation procedures can cause damage. ESD damage can range from subtle performance degradation to complete device failure. Precision integrated circuits may be more susceptible to damage because very small parametric changes could cause the device not to meet its published specifications.

NOTE4: The human body model is a 100pF capacitor discharged through a 1.5kΩ resistor into each pin. Test method: ESDA/JEDEC

JS-001

NOTE5: Test Condition: ESDA/JEDEC JS-002-2018

NOTE6: Test Condition: JEDEC STANDARD NO.78E

## Electrical Characteristics

Minimum and maximum limits apply over the full operating ambient temperature range ( $-40^{\circ}\text{C} \leq T_A \leq 85^{\circ}\text{C}$ ), typical values are at  $T_A = 25^{\circ}\text{C}$ , and  $V_{IN} = 3.6\text{ V}$  (unless otherwise noted).

PARAMETER		TEST CONDITIONS	MIN	TYP	MAX	UNIT
<b>Power supply</b>						
$V_{IN}$	Input operating range		2.7		5.5	V
$I_{SHDN}$	Shutdown current	$V_{IN} = 5.5\text{V}$ , $HWEN = \text{GND}$		0.1	1	$\mu\text{A}$
$I_{SB}$	Standby current	Standby, $V_{IN} = 4.2\text{V}$ , $HWEN = \text{SDA} = \text{SCL} = 1.8\text{V}$		7	10	$\mu\text{A}$
UVLO	Input under voltage lockout	Rising edge		2.4	2.6	V
UVLO <sub>HYS</sub>	UVLO hysteresis			0.15		V
$V_{POR}$	Power on reset voltage	falling edge		1.7	2	V
<b>BOOST</b>						
$I_{MATCH}$	LED current matching ILED1 to ILED2 to ILED3	$50\ \mu\text{A} \leq I_{LED} \leq 29.6\ \text{mA}$ , $2.7\ \text{V} \leq V_{IN} \leq 5\ \text{V}$ (linear or exponential mode)	-1%		+1%	
Accuracy	Absolute accuracy (ILED1, ILED2, ILED3)	$50\ \mu\text{A} \leq I_{LED} \leq 29.6\ \text{mA}$ , $2.7\ \text{V} \leq V_{IN} \leq 5\ \text{V}$ (linear or exponential mode)	-3%		+3%	
$I_{LED\_MIN\_LIN}$	Minimum LED current (per string) with linear	I <sup>2</sup> C current control at $I_{FS}=20\text{mA}$	8.8	9.77	10.7	$\mu\text{A}$
$I_{LED\_MIN\_EXP}$	Minimum LED current (per string) with exponential		48.5	50	51.5	$\mu\text{A}$
$I_{LED\_MAX}$	Maximum LED current in Backlight mode (per string)		28.8	29.6	30.4	mA
$I_{LED\_MAX\_FL}$	Maximum LED current in flash mode (per string)		77.5	79.9	82.3	mA
$V_{HR}$	Regulated current sink headroom voltage	ILED = 20mA	255	285	325	mV
		ILED = 5 mA	120	150	180	
$V_{HR\_MIN}$	Current sink minimum headroom voltage	ILED = 5mA down to 95%		30	80	mV

PARAMETER		TEST CONDITIONS		MIN	TYP	MAX	UNIT
Efficiency	Typical efficiency	$V_{IN} = 3.8\text{ V}$ , ILED = 5mA/string, Typical (3P7S) Application circuit			87%		
$R_{NMOS}$	NMOS switch on resistance	$I_{SW} = 250\text{ mA}$			0.23	0.4	$\Omega$
$I_{LIMIT}$	NMOS switch current limit	$2.7\text{ V} \leq V_{IN} \leq 5\text{ V}$	OCP = 00	0.72	0.9	1.08	A
			OCP = 01	1.53	1.8	2.07	
			OCP = 10	2.38	2.7	3.02	
			OCP = 11	3.03	3.4	3.78	
$V_{OVP}$	Output overvoltage protection	$2.7\text{ V} \leq V_{IN} \leq 5\text{ V}$	OVP = 000	16	17.5	19	V
			OVP = 001	22.5	24	25.5	
			OVP = 010	29.5	31	32.5	
			OVP = 011	36.5	38	39.5	
			OVP = 1XX	40	41.5	43	
OVP Hysteresis					0.5		V
$f_{SW}$	Switching frequency	$2.7\text{ V} \leq V_{IN} \leq 5\text{ V}$ boost frequency shift = 0	Boost Frequency select = 0	475	500	525	kHz
			Boost Frequency select = 1	950	1000	1050	
$D_{MAX}$	Maximum boost duty cycle			92%	94%		
Over Temperature Protection(OTP)	IC thermal shutdown threshold				160		$^{\circ}\text{C}$
OTP Hysteresis	IC thermal shutdown hysteresis				15		
<b>LOGIC CONTROL</b>							
Min $f_{PWM}$	Minimum PWM input frequency					50	Hz
Max $f_{PWM}$	Maximum PWM input frequency			50			kHz
$t_{MIN\_ON}$	Minimum pulse ON time	Sample rate = 24 MHz				183	ns
		Sample rate = 4 MHz				1100	
		Sample rate = 800 kHz				5500	

PARAMETER		TEST CONDITIONS	MIN	TYP	MAX	UNIT
t <sub>MIN_OFF</sub>	Minimum pulse OFF time	Sample rate = 24 MHz			183	ns
		Sample rate = 4 MHz			1100	
		Sample rate = 800 kHz			5500	
PWM <sub>RES</sub>	Input PWM duty resolution	1.6 kHz ≤ f <sub>PWM</sub> ≤ 12 kHz, PWM hysteresis = 00, PWM sample rate = 11		11		bits
t <sub>PWM_STBY</sub>	PWM shutdown period	Sample rate = 24 MHz	0.61	0.68	0.75	ms
		Sample rate = 4 MHz	3.69	4.1	4.51	
		Sample rate = 800 kHz	18.4	20.5	22.6	
V <sub>IH</sub>	Input logic high	HWEN, PWM inputs	1.4		V <sub>IN</sub>	V
V <sub>IL</sub>	Input logic low	HWEN, PWM inputs	0		0.4	
R <sub>PDEN</sub>	HWEN pull down resistor		300	400	500	kΩ
R <sub>PDPWM</sub>	PWM pull down resistor		300	400	500	kΩ
t <sub>GLITCH</sub>	PWM input glitch rejection	PWM pulse filter = 00		0	15	ns
		PWM pulse filter = 01	60	100	140	
		PWM pulse filter = 10	90	150	210	
		PWM pulse filter = 11	120	200	280	
<b>I<sup>2</sup>C INTERFACE, see Figure1</b>						
V <sub>IH</sub>	Input logic high		1.4		V <sub>IN</sub>	V
V <sub>IL</sub>	Input logic low		0		0.4	V
V <sub>OL</sub>	SDA Output Logic Low	I <sub>SDA</sub> = 3mA			0.4	V
F <sub>SCL</sub>	Interface Clock frequency				400	kHz
T <sub>HD: STA</sub>	(Repeat-start) Start condition hold time		0.6			μs
T <sub>LOW</sub>	Low level width of SCL		1.3			μs
T <sub>HIGH</sub>	High level width of SCL		0.6			μs
T <sub>SU: STA</sub>	(Repeat-start) Start condition setup time		0.6			μs
T <sub>HD: DAT</sub>	Data hold time		0			μs
T <sub>SU: DAT</sub>	Data setup time		0.1			μs



PARAMETER		TEST CONDITIONS	MIN	TYP	MAX	UNIT
$T_R$	Rising time of SDA and SCL				0.3	$\mu s$
$T_F$	Falling time of SDA and SCL				0.3	$\mu s$
$T_{SU:STO}$	Stop condition setup time		0.6			$\mu s$
$T_{BUF}$	Time between start and stop condition		1.3			$\mu s$

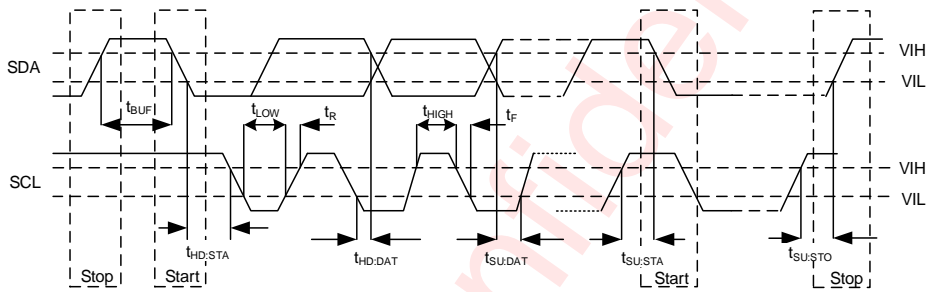
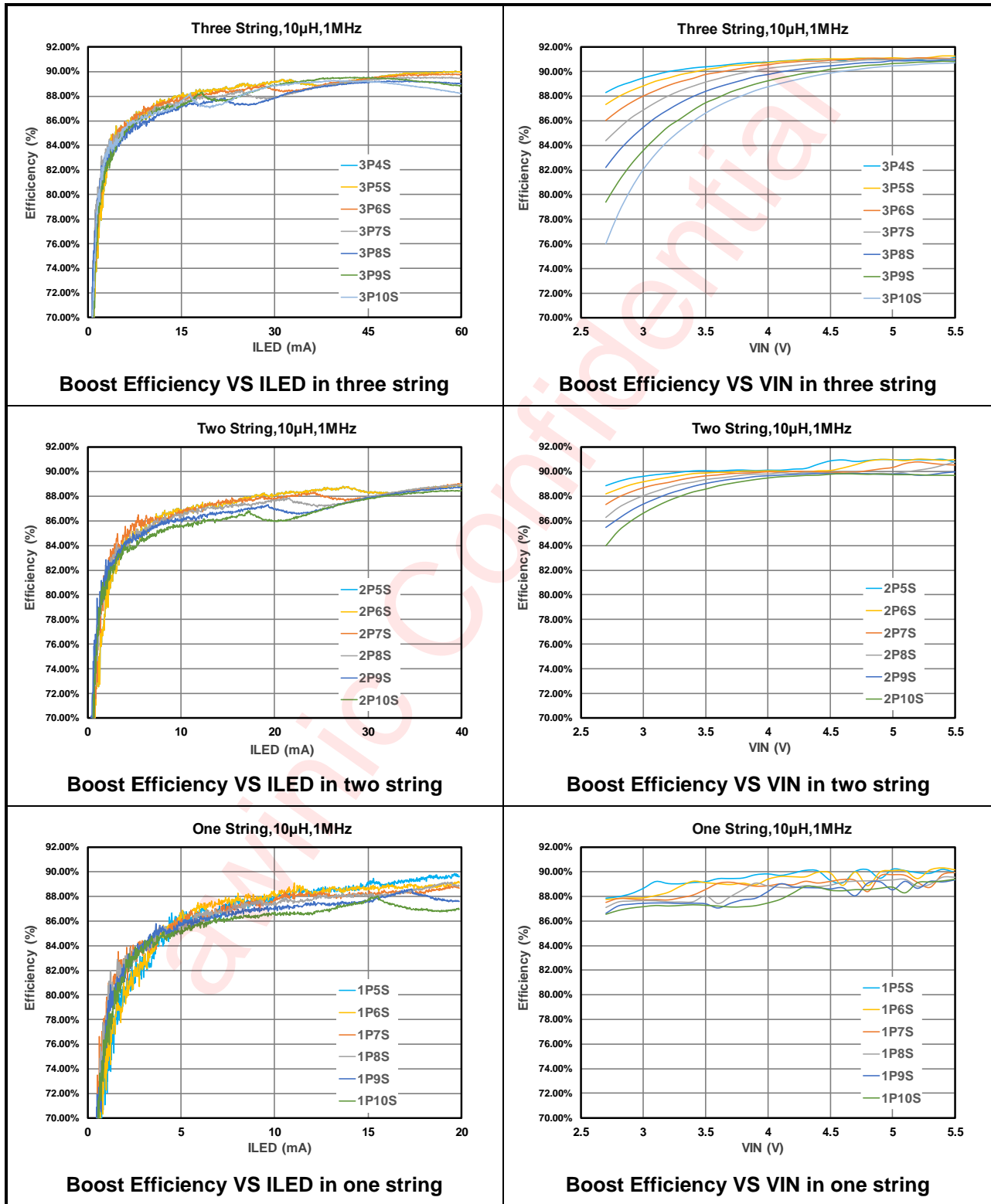

Figure 1. I<sup>2</sup>C Interface Timing

### Typical Characteristics

L=LPS4018-103ML and D=NSR0340V2T1G as noted in graphs, LEDs are 17-21/T1D-CP2R1TY/3T, temperature = 27°C, VIN = 3.8 V, unless otherwise noted.



L=LPS4018-472ML and D=NSR0340V2T1G as noted in graphs, LEDs are 17-21/T1D-CP2R1TY/3T, temperature = 27°C, VIN = 3.8 V, unless otherwise noted.

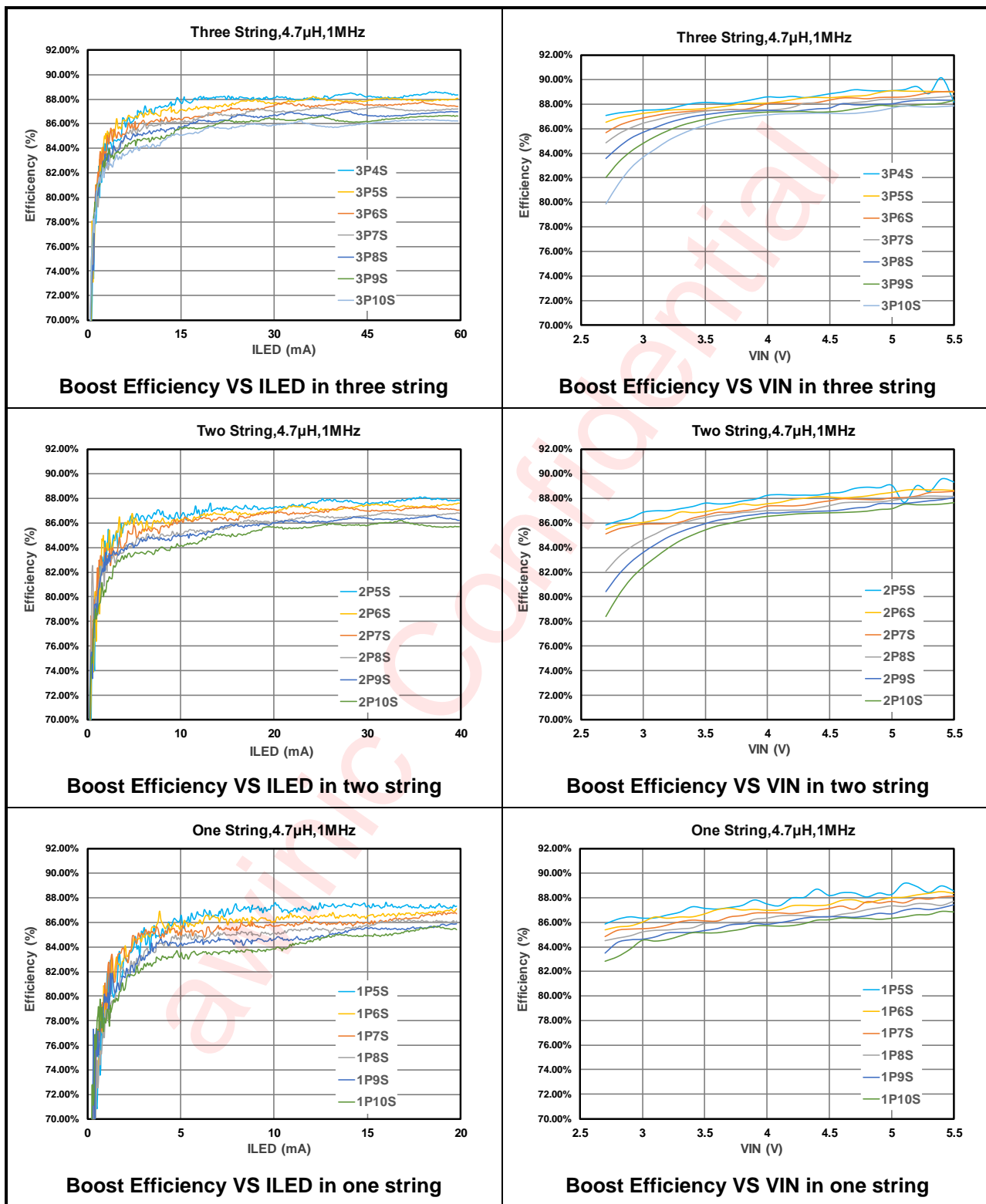

L=LPS4018-103ML and D=NSR0340V2T1G as noted in graphs, LEDs are 17-21/T1D-CP2R1TY/3T, temperature = 27°C, VIN = 3.8 V, unless otherwise noted.

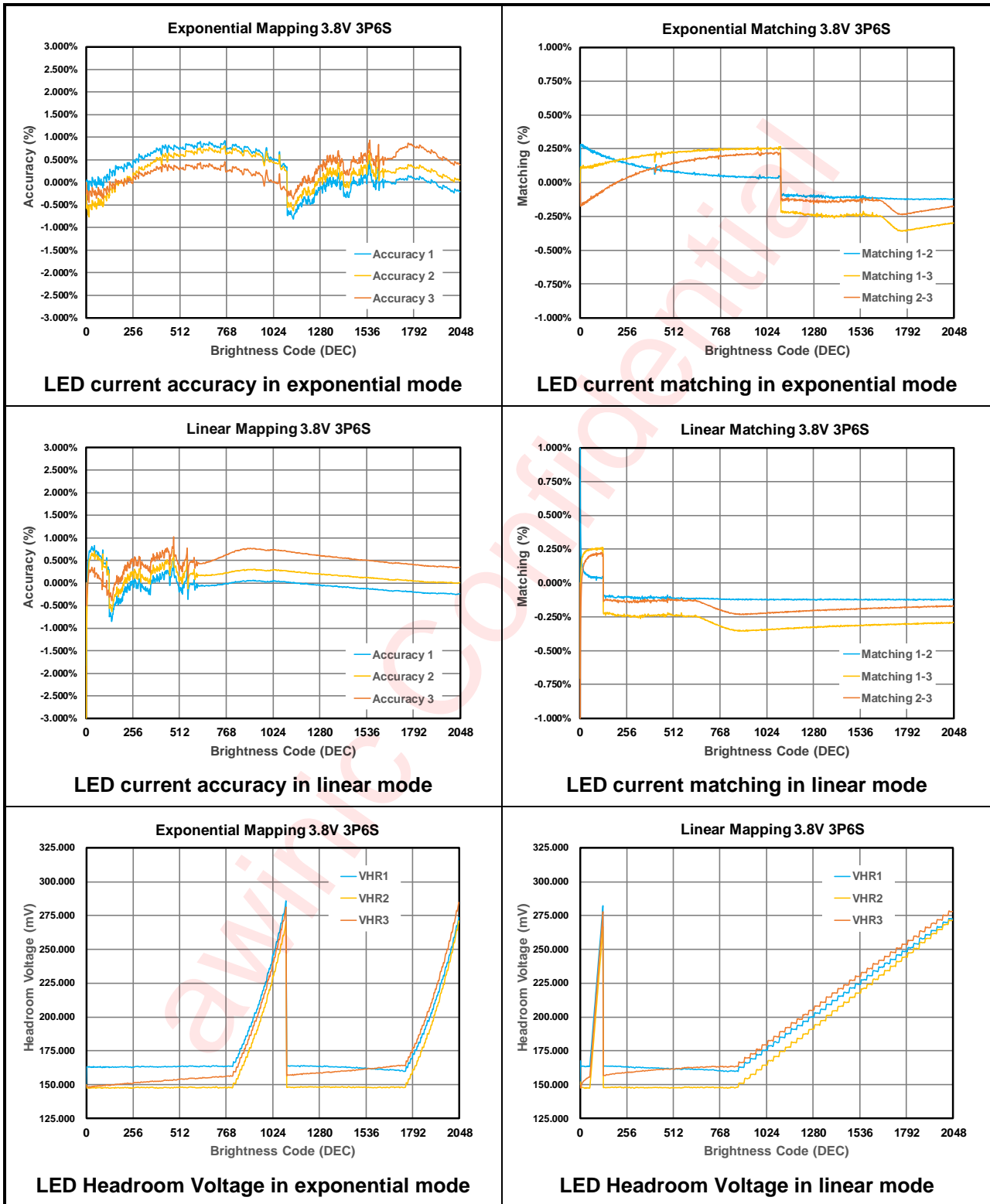

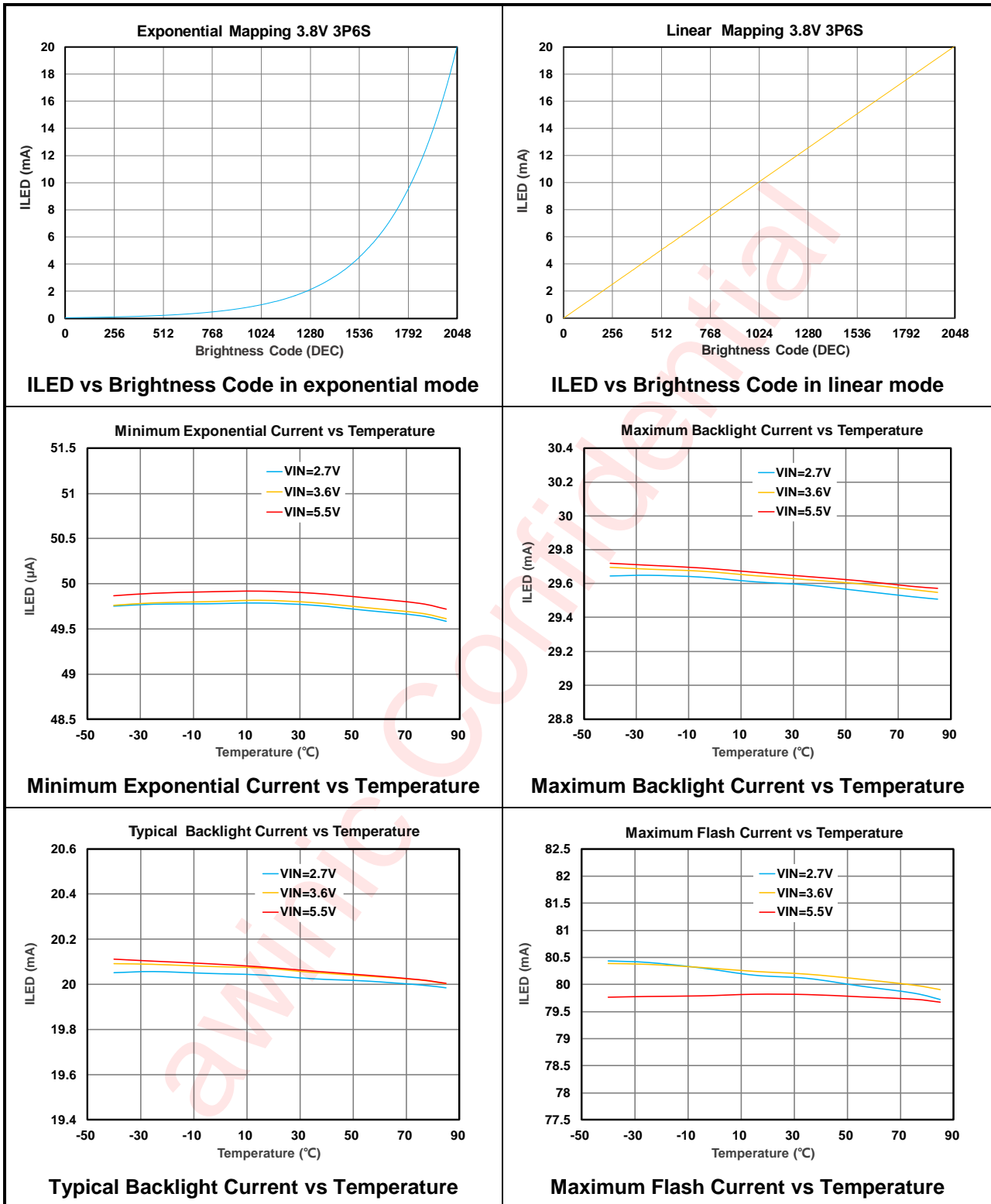

## Detailed Functional Description

AW99703 is an inductive boost converter for WLED backlight display. AW99703 have three high-voltage LED strings with high current accuracy and string-to-string matching.

AW99703 supports 11 bits resolution analog dimming via I<sup>2</sup>C register set or via PWM duty changed. AW99703 also supports flash mode by enhancing sink current up to 79.9mA/string with the flash timeout protection.

### Hardware Enable & Standby Mode

When HWEN is pulled low, AW99703 enters Shutdown mode, all I<sup>2</sup>C registers are reset to default state, and the I<sup>2</sup>C interface is disabled, the device will not respond to any I<sup>2</sup>C command.

When HWEN is pulled high, the device goes into Standby mode, Whether the I<sup>2</sup>C interface is enabled depends on PORN state. When VIN>2V, PORN goes high and the device can respond to I<sup>2</sup>C command for at least  $t_{reset}=250\mu s$ .

Based on HWEN's connection and the power-up sequences, there are 3 situations shown in [Figure 2](#), [Figure 3](#) and [Figure 4](#).

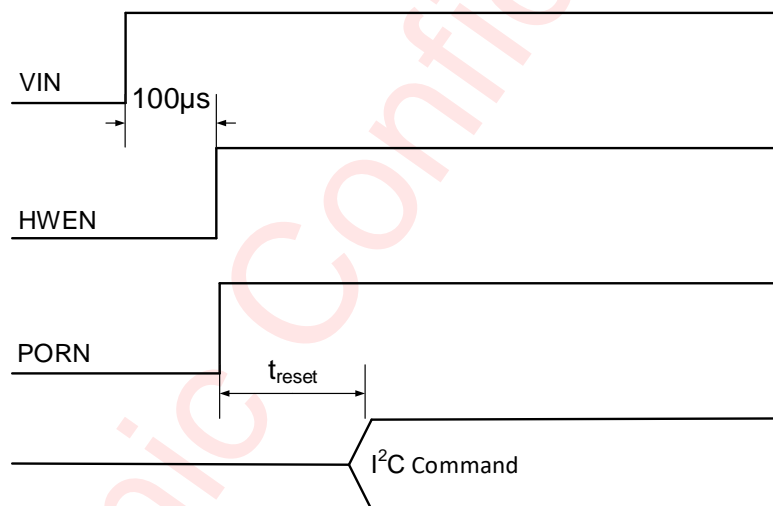

Figure 2. Power Up Sequence with HWEN Enabled after VIN

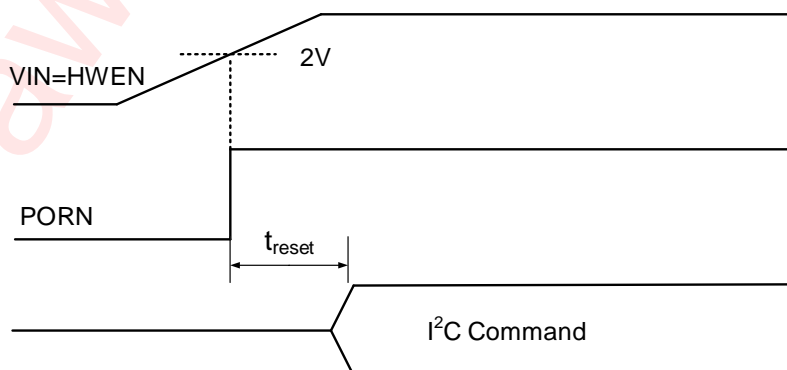

Figure 3. Power Up Sequence with HWEN Tied to VIN

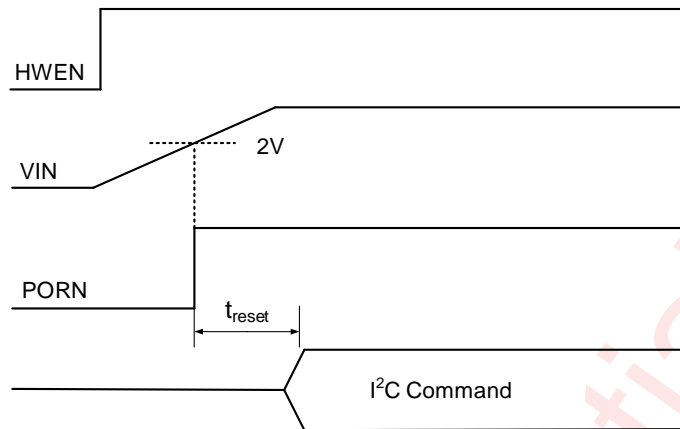

Figure 4. Power Up Sequence with HWEN Enabled before VIN

Both HWEN and I<sup>2</sup>C command can be used to turn off the LED current, but there are some differences:

If pulling HWEN low, the LED current will be turned off immediately without any ramp.

If HWEN is keeping high, the LED current will ramp down with a fixed time by controlling I<sup>2</sup>C command to turn off backlight/flash mode.

### Operation States

AW99703 has 4 states referred to [Table 1](#), which are switched by HWEN or I<sup>2</sup>C command. When HWEN is pulled low, AW99703 enters Shutdown state and the leakage current is less than 1μA.

If HWEN is pulled high without I<sup>2</sup>C command, device enters Standby state. If SCL/SDA's pull up voltage is much less than VIN voltage, it can cause a small leakage current and the current is less than 10μA.

Table 1. AW99703 Operating States

HWEN	Register 0x02[1:0]	States
Low	00 (default)	Shutdown
High	00	Standby
High	01	Backlight
High	1X	Flash

Writing 2'b01 or 2'b1X can enable device to enter Backlight mode or Flash mode. Writing 2'b00 can close backlight or exit Flash mode.

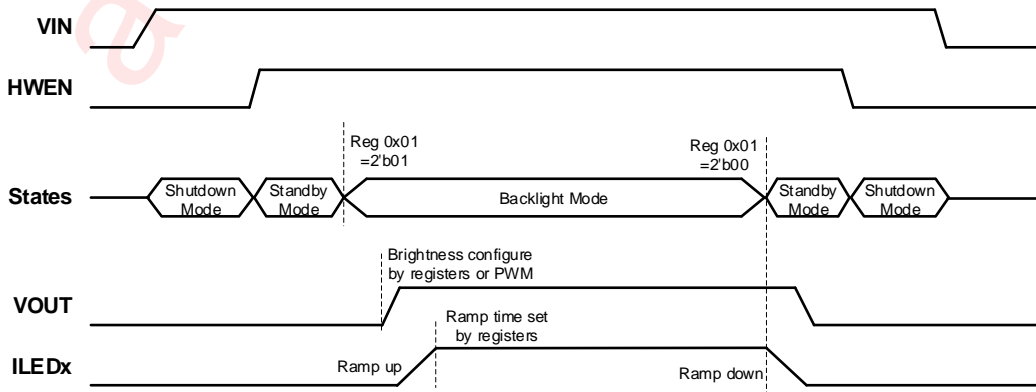

Figure 5. Operation Timing of AW99703 Backlight Mode

## Backlight I<sup>2</sup>C Dimming

AW99703 has 11-bit dimming level, including the 8-bit MSBs from LED Brightness MSB Register 0x07 Bits[7:0] and the 3-bit LSBs from LED Brightness LSB Register 0x06 Bits[2:0]. When programming 11-bit brightness code, the 3-bit LSBs should be programmed primarily, then the 8-bit MSBs are programmed.

There are two different shapes to map the dimming code to the LED current: linear and exponential, which are programmed by Mode Register 0x02 Bits[2]. These two modes determine the transfer characteristic of brightness code to LED current.

### Linear Mapping

In the 11-bit linear mapped mode, per channel of the LED current follows the equation:

$$I_{LED\_BL} = I_{FS} \times D_{PWM} \times \frac{Code}{2047} \quad (Code=0\sim2047)$$

where  $I_{FS}$  is the backlight full-scale LED current,  $D_{PWM}$  is the input PWM duty cycle if PWM dimming is enabled, otherwise  $D_{PWM}=1$ , Code is an 11-bit I<sup>2</sup>C brightness code.

When 11-bit brightness code is set to 0, all current sinks and boost converter will be disabled, LED will be turned off.

### Exponential Mapping

In the 11-bit exponential mapped mode, per channel of the LED current follows the equation:

$$I_{LED\_BL} = I_{FS} \times D_{PWM} \times \frac{1.002931237^{Code}}{400} \quad (Code=1\sim2047)$$

When 11-bit brightness code is set to 0, all current sinks and boost converter will be disabled, LED will be turned off.

In the 11-bit exponential mapped mode, each code step (0.293%) is small enough under low LED current condition so that the transition from one code to the next is smooth to the human eye.

## Backlight PWM Dimming

AW99703 converts the PWM input duty cycle into an 11-bit digital code  $D_{PWM}$ . The PWM dimming function can be enabled or disabled by the Mode Register 0x02 Bit[4].

The PWM input frequency range is 50Hz to 50kHz, and there are three selectable sample rates (24MHz/4MHz/800kHz) for the PWM input, programmed by PWM Control Register 0x08 Bits[7:6].

To achieve the maximum resolution of PWM duty cycle, the input PWM duty cycle resolution must be  $\geq 11$  bits, and the PWM sample period ( $1/f_{SAMPLE}$ ) must be smaller than the minimum PWM input pulse width. **Figure 6** shows the possible dimming resolutions based on the input PWM frequency.

For flash mode, the current is not related to the input PWM duty cycle.



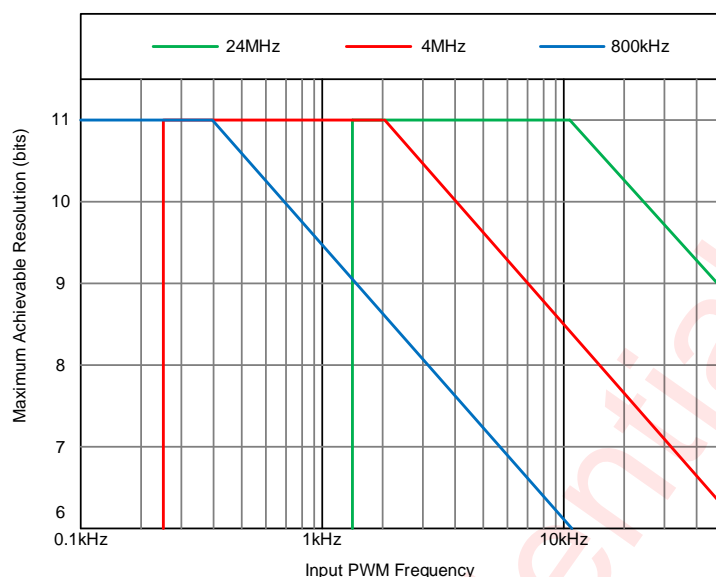

Figure 6. PWM Sample Rate, Resolution and PWM Input Frequency

## Backlight PWM Hysteresis

PWM hysteresis helps filter out jitter of the PWM input that could cause LED flicker (especially at light currents), AW99703 owns seven selectable hysteresis settings to prevent jitter at the input PWM signal. The hysteresis only works during the opposite direction of PWM duty cycle change. When the change is larger or equal to the number of LSBs programmed, the output LED current starts to follow the change. Once the initial hysteresis has been overcome and the direction in duty cycle change remains the same, the PWM duty will change without hysteresis.

**Table 2** shows the relationship between the minimum LSB(s) and the PWM duty cycle hysteresis. The drawback of setting PWM hysteresis too high is that the output current becomes less accurate due to the hysteresis.

Table 2. PWM input Hysteresis

PWM Register 0x08 Bits[4:2]	Minimum LSB(s)	PWM Duty Cycle Hysteresis
000	0	0/2047=0%
001	1 LSB	1/2047=0.049%
010	2 LSBs	2/2047=0.098%
011	3 LSBs	3/2047=0.147%
100	4 LSBs	4/2047=0.195%
101	5 LSBs	5/2047=0.244%
110	6 LSBs	6/2047=0.293%
111	7 LSBs	7/2047=0.342%

## PWM Timeout

PWM timeout feature will turn off the boost output, if the PWM is enabled and there is no PWM pulse detected during some time. The timeout duration is determined by the PWM Sample Rate, so there is three minimum

supported PWM input frequency corresponding to the PWM Sample Rate. The sample rate, timeout, minimum supported PWM frequency and maximum recommended PWM frequency for 11 bits resolution are summarized in [Table 3](#).

**Table 3. PWM input Hysteresis**

SAMPLE RATE	TIMEOUT	MINIMUM SUPPORTED PWM FREQUENCY	MAXIMUM RECOMMENDED PWM FREQUENCY FOR 11 BITS RESOLUTION
800kHz	20.5ms	50Hz	390Hz
4MHz	4.1ms	0.35kHz	1.95kHz
24MHz	0.68ms	1.6kHz	11.7kHz

### Full-scale LED Current in Backlight Mode

The full-scale LED current ( $I_{FS}$ ) is programmed by the LED current Register 0x03 Bits[7:3]. Full scale current ranges from 4.8mA to 29.6mA with 0.8mA/step and 20mA as the default.  $I_{FS}$  is defined when PWM dimming duty cycle  $D_{PWM}$  is 100% and the I<sup>2</sup>C brightness code is 2047.

### Flash LED Current

The flash LED current of every channel is programmed by Flash Setting Register 0x0b Bits[3:0].

The equation is:

$$I_{LED\_FLASH} = \left(1 + \frac{Code\_FL + 2}{10}\right) \times 29.6mA \quad (Code=0\sim 15)$$

Where Code\_FL is set by Flash Setting Register 0x0b Bits[3:0]. Flash current ranges from 35.52mA to 79.92mA, with 59.2mA as the default.

### Flash Timeout

The flash timeout is programmed by Flash Setting Register 0x0b Bits[7:4] from 0ms to 1.5sec with 100ms/step, and default value is 500ms. If the switching frequency is shifted up or down, the flash timeout will be decreased or increased synchronously.

### Turn On/Off Ramp

When AW99703 is enabled from Standby mode to backlight mode or flash mode, LED current ramp up time is programmed by Turn ON/OFF Ramp Register 0x09[7:4], When AW99703 is disabled to Standby mode, LED current ramp down time is programmed by Turn ON/OFF Ramp Register 0x09[3:0]. Both turn on and off time have 16 options, its range is from 512μs to 16384ms, with 8ms as default. Please note that if the switching frequency is shifted up or down, all ramp time will be decreased or increased synchronously.

### Dimming Transition Ramp

The transition ramp time can be programmed by Register 0x0a after the turn on ramp is done. If the LED current is changed from one to another by I<sup>2</sup>C brightness code or PWM duty cycle, the current transition ramp time will follow the value of the Register 0x0a programmed.

If the LED current is changed by I<sup>2</sup>C brightness code, the transition ramp time can be programmed by 0x0a

Bits[3:0]. For Code 0001~1111, there are 15 programmable options (128ms ~ 4096ms) of the ramp time, it is the total time of ramp independent of the brightness code change as shown in **Figure 7**. The ramp time from code1 to code2 is the same as that from code1 to code3. For Code 0000, the slope of the ramp is a fixed value:  $t_{step}=1\mu s/step$ , so the final transition ramp time is dependent on the 11-bit brightness code change. As shown in **Figure 8**, the ramp time from code1 to code2 is equal to  $|code1-code2| \times 1\mu s/step$ .

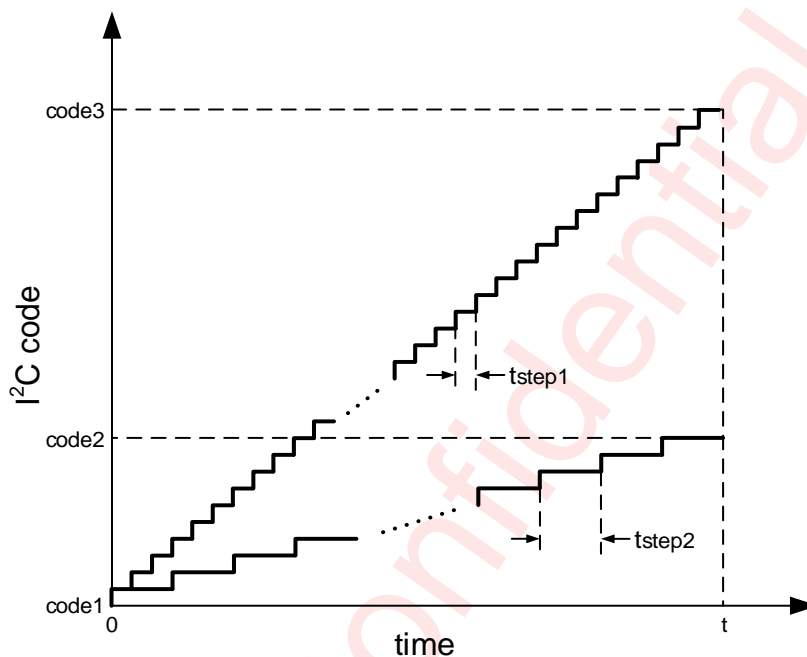

**Figure 7. Only I<sup>2</sup>C Transition Ramp when 0x0a bits[3:0]=0001~1111**

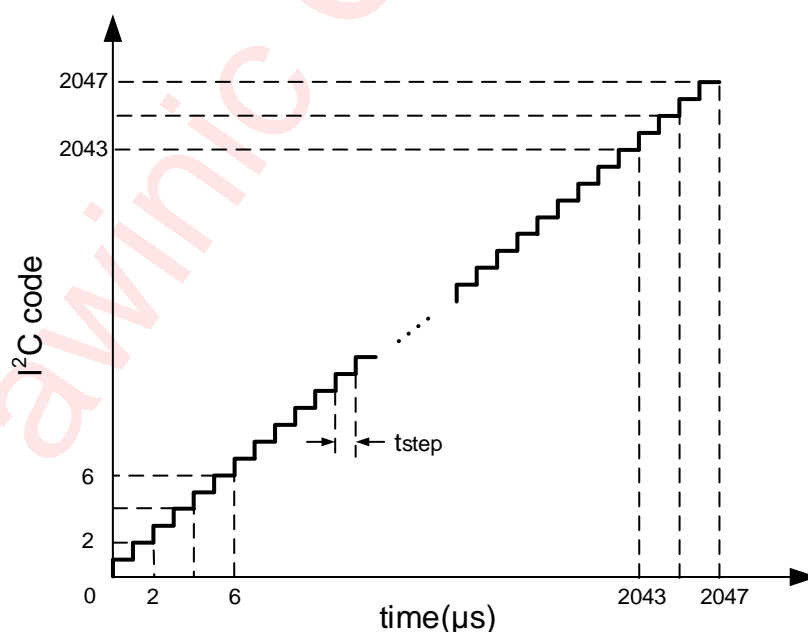

**Figure 8. Only I<sup>2</sup>C Transition Ramp when 0x0a bits[3:0]=0000**

If the LED current is changed by PWM duty cycle, the transition ramp time can be programmed by 0x0a Bits[6:4], which determines the time of the duty cycle change from the minimum PWM duty cycle to the

maximum PWM duty cycle. In other words, its slope is fixed, so the final transition ramp time is dependent on the change of the PWM duty cycle.

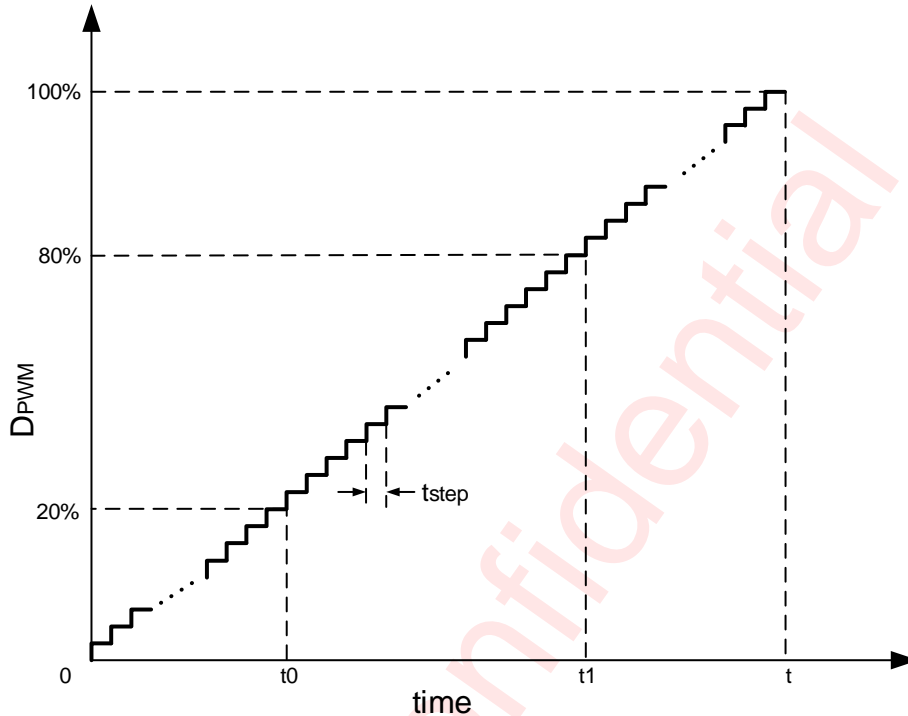

**Figure 9. Only PWM Transition Ramp**

As shown in [Figure 9](#),  $0x0a[6:4]$  determine how long it takes from  $D_{PWM}=0$  to  $D_{PWM}=100\%$ , which is  $t$ . Therefore, if  $D_{PWM}$  is changed from 20% to 80%, the ramp time  $t_1-t_0=(80\%-20\%) \times t$ . In other words, the different PWM ramp time decides the different  $t_{step}$ .

When the system switches between backlight mode and flash mode, the LED current transition ramp time will always choose  $1\mu\text{s}/\text{step}$  of I<sup>2</sup>C brightness code and PWM duty cycle change, to minimize the transition time. Please note that if the switching frequency is shifted up or down, all ramp time will be decreased or increased synchronously.

## Channel Enable/Disable

All channels are enabled as default and can be enabled or disabled through LED Current Register  $0x03$  Bits [2:0]. Writing  $3'b000$  to closing all channels will turn off backlight without ramp down, so it is not recommended. Turning off backlight by entering Standby mode or pulling HWEN low can provide an ultra-low consumption.

## Switching Frequency

There are two switching frequencies of boost converter to be programmed by Control Register  $0x04$  Bit[5]: 500kHz and 1MHz, with 1MHz as default. Once the switching frequency is set, this nominal value can be shifted up or down via  $0x04$  Bits[7:6]. This function is to prevent switching noise interference if the selected switching frequency is within the sensitive frequency range of the system. The adjustment of the switching frequency can optimize the efficiency under load current condition.

## EMI Reduction

Programmable Slew Rate Control uses a combinational drivers for boost switch. Enabling all drivers allows boost switch on/off transition time to be the shortest, enabling just one driver allows boost switch on/off transition time to be the longest. The longer the transition time, the lower the switching noise on the SW pin. Note that the shortest transition time brings the best efficiency as the switching losses are the lowest.

**Figure 10** shows the EMI programmable steps, and the Programmable Slew Rate Control operates at the Boost Control2 Register 0x05 Bits[5:3].

Slow1,slow2 and slow3 represent slow, slower and slowest.Fast1,fast2,fast3 and fast4 mean getting faster in turn.

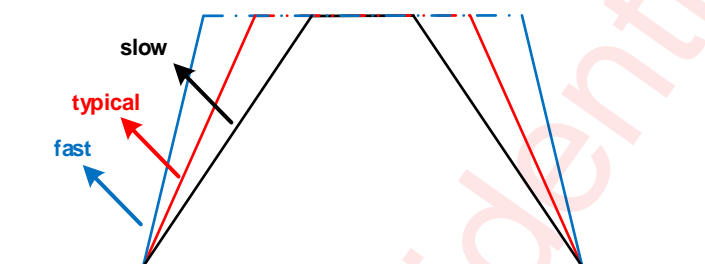

Figure 10. EMI Reduction Operation

## Auto-Switching Frequency

In order to optimize efficiency between frequency and load current, the AW99703 provides an automatic frequency change mode. This function can be enabled or disabled by Boost Control2 Register 0x05 Bit[7], with disabled as default. When this function is disabled, the switching frequency operates at the programmed frequency (Register 0x04 Bit[5]), no matter what LED current is.

Auto-frequency mode operates through 2 programmable registers: Auto Frequency High Threshold (Register 0x0c) and Auto Frequency Low Threshold (0x0d). The boost switching frequency is determined by the comparison results between 8 MSBs of the brightness register (Register 0x07) and 8-bit High/Low Threshold. The high threshold determines the switchover from 1MHz to 500kHz. The low threshold determines the switchover from 500kHz to 250kHz. Please note that the 250kHz frequency is only accessible in auto-frequency mode and its maximum duty ( $D_{MAX}$ ) cycle is restricted to 50%. **Table 4** details the boundaries for this mode. **Table 5** provides a guideline for the low threshold setting, the actual setting needs to be verified in the application.

Table 4. Auto-Switching Frequency Operation

BRIGHTNESS CODE MSBs (Register 0x07 Bits[7:0])	BOOST SWITCHING FREQUENCY
<Auto Frequency Low Threshold (Register 0x0d Bits[7:0])	250 kHz ( $D_{MAX} = 50\%$ )
> Auto Frequency Low Threshold (Register 0x0d Bits[7:0]) and < Auto Frequency High Threshold (Register 0x0c Bits[7:0])	500 kHz
$\geq$ Auto Frequency High Threshold Register 0x0c Bits[7:0])	1 MHz

Table 5. Auto Frequency 250 kHz Threshold Settings

CONDITION ( $V_f = 3.2\text{ V}$ , $I_{LED} = 25\text{ mA}$ )	INDUCTOR ( $\mu\text{H}$ )	RECOMMENDED AUTO FREQUENCY LOW THRESHOLD MAXIMUM VALUE (NO SHIFT)	OUTPUT POWER AT AUTO FREQUENCY SWITCHOVER (W)
3 × 4 LEDs	10	0x17	0.079
3 × 5 LEDs	10	0x15	0.089
3 × 6 LEDs	10	0x13	0.097
3 × 7 LEDs	10	0x11	0.101
3 × 8 LEDs	10	0x0f	0.102

awinic Confidential

## Inductor Select

The AW99703 can use inductors in the range of  $4.7\mu\text{H}$  to  $10\mu\text{H}$ . In order to optimize the converter loop response, the minimum inductor select bit Boost Control Register 0x05 Bit[6] should be set depending on which value of inductance is chosen. For  $10\mu\text{H}$  inductors, this bit should be set to 1. For less than  $10\mu\text{H}$ , this bit should be set to 0.

## Auto Headroom Voltage

The adaptive headroom voltage (VHR) regulates the output voltage to supply the necessary minimal headroom voltage for the current sinks to provide the set ILED current. [Figure 11](#) shows the typical variation of VHR with LED current. It is implied that the reference voltage of Error Amplifier is adjusted with the LED current changing, since the current sinks need less headroom at lower LED current than at higher LED current.

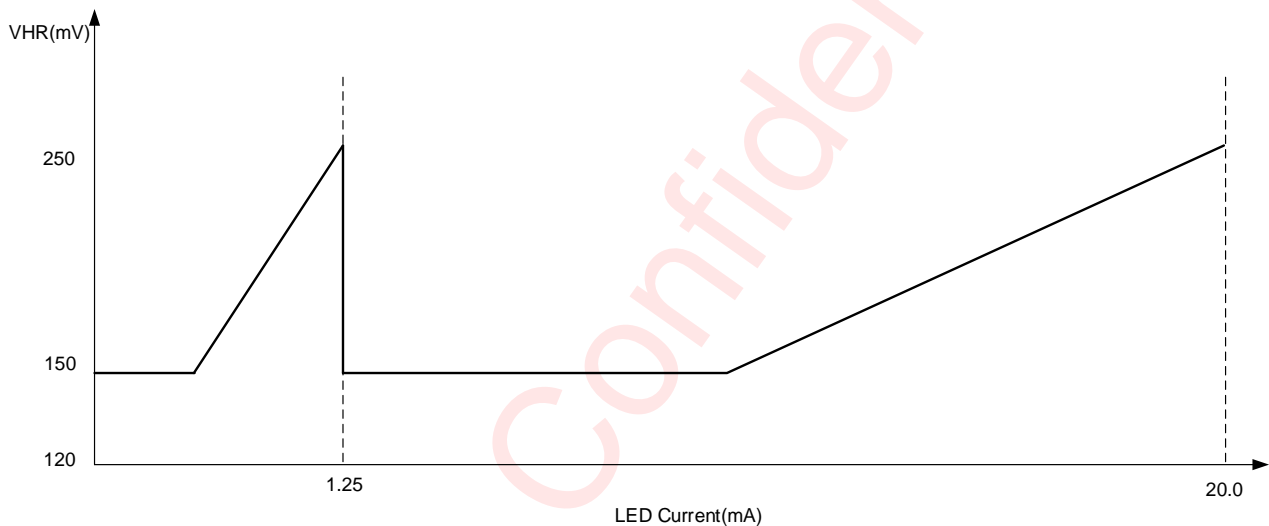

**Figure 11. AW99703 Typical Regulated Headroom Voltage vs Programmed LED Current**

## Over Voltage Protection (OVP)

The OVP block monitors the boost output voltage ( $V_{\text{OUT}}$ ) and protects OUT and SW from exceeding safe operating voltages. There are five programmable OVP thresholds (17.5V, 24V, 31V, 38V and 41.5V) by Boost Control1 Register 0x04 Bits[4:2].

After OVP Flag is set, user needs to restart the IC by toggling HWEN or sending software reset command or reading back fault register.

## Over Current Protection (OCP)

The OCP (over current protection) protects device from high current density by a cycle-by-cycle current limit of internal high voltage NFET. Once inductor peak current exceeds the threshold, the NFET will be turn off immediately. Then the OCP Flag is set and latched. The AW99703 has four selectable OCP thresholds (900mA, 1800mA, 2700mA and 3400mA). These are programmable in Boost Control1 Register 0x04 Bits[1:0].

After OCP Flag is set, user needs to restart the IC by toggling HWEN or sending software reset command or reading back fault register .

## Over Temperature Protection (OTP)

OTP (Over temperature protection) function monitors the IC's junction temperature in real-time. If it reaches 165°C, the boost converter stops switching and current sinks are all disabled. Once it drops by 15°C, the chip will resume to its previous settings.

If temperature goes above 165°C for more than 64μs, the OTP Flag is set and latched. After OTP Flag is set, user needs to restart the IC by toggling HWEN or sending software reset command or reading back fault register.

## LED Fault Detection

AW99703 is equipped with LED short/open detection function. LED short condition can be detected when the voltage between  $V_{OUT}$  and any enabled current sink input has dropped below 1V. LED open condition can be detected when any enabled current sink input  $\leq 40\text{mV}$  at the rising edge of OVP Flag.

## UVLO

Under voltage lock-out (UVLO) is integrated to detect the input voltage  $V_{IN}$ . Once  $V_{IN}$  drops below UVLO falling threshold, the current sinks are disabled and the boost converter stops switching. If  $V_{IN}$  increases above UVLO rising threshold, the boost converter and the current sinks will resume to their previous settings.

## Software Reset

Writing 0x01 to Soft Reset Register 0x01 Bit[0] via I<sup>2</sup>C interface will reset all internal circuits and configuration registers. Then the device will not respond to any I<sup>2</sup>C command for 2ms.



## I<sup>2</sup>C Interface

The device supports the I<sup>2</sup>C serial bus and data transmission protocol. It operates as a slave on the I<sup>2</sup>C bus. The maximum clock frequency specified by the I<sup>2</sup>C standard is 400kHz. Connect to the bus are made via the open-drain I/O pins SCL and SDA. The pull-up resistor can be selected in the range of 1kΩ~10kΩ and the typical value is 4.7kΩ when I<sup>2</sup>C frequency is 400kHz. Different high level from 1.8V to 3.3V of this I<sup>2</sup>C interface is supported.

### Device Address

AW99703 7-bit slave address (A7~A1) is 0110110 binary (0x36H). After the START condition, the I<sup>2</sup>C master sends the 7-bit device address followed by an eighth (A0) read or write bit (R/W). R/W= 0 indicates a WRITE and R/W = 1 indicates a READ.

Table 6. Device Address

A7	A6	A5	A4	A3	A2	A1	A0
0	1	1	0	1	1	0	R/W

### I<sup>2</sup>C Start/Stop

I<sup>2</sup>C start: SDA changes from high level to low level when SCL is high level.

I<sup>2</sup>C stop: SDA changes from low level to high level when SCL is high level.

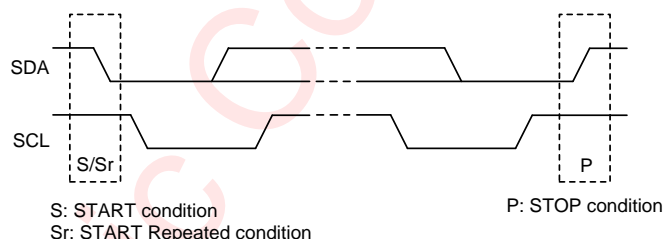

Figure 12. I<sup>2</sup>C Start/Stop Condition Timing

### Data Validation

When SCL is high level, SDA level must be constant. SDA can be changed only when SCL is low level.

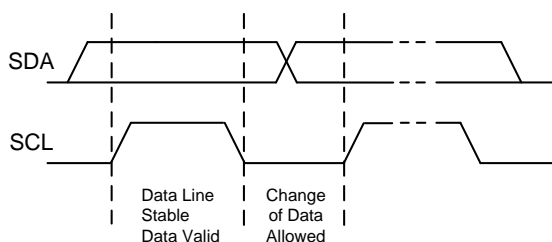

Figure 13. Data Validation Diagram

## ACK (Acknowledgement)

ACK means the successful transfer of I<sup>2</sup>C bus data. After master sends an 8-bit data, SDA must be released; SDA is pulled to GND by slave device when slave acknowledges.

When master reads, slave device sends 8-bit data, releases the SDA and waits for ACK from master. If ACK is send and I<sup>2</sup>C stop is not send by master, slave device sends the next data. If ACK is not send by master, slave device stops to send data and waits for I<sup>2</sup>C stop.

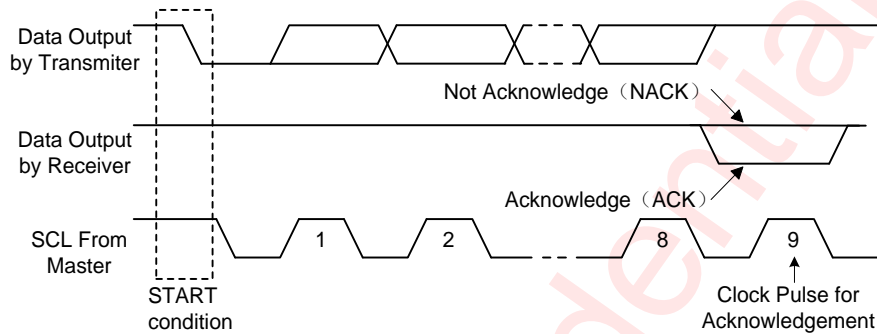

Figure 14. I<sup>2</sup>C ACK Timing

## Write Cycle

One data bit is transferred during each clock pulse. Data is sampled during the high state of the serial clock (SCL). Consequently, throughout the clock's high period, the data should remain stable. Any changes on the SDA line during the high state of the SCL and in the middle of a transaction, aborts the current transaction. New data should be sent during the low SCL state. This protocol allows a single data line to transfer both command/control information and data using the synchronous serial clock.

Each data transaction is composed of a start condition, a number of byte transfers (set by the software) and a stop condition to terminate the transaction. Every byte written to the SDA bus must be 8 bits long and is transferred with the most significant bit first. After each byte, an Acknowledge signal must follow.

In a write process, the following steps should be followed:

- Master device generates START condition. The "START" signal is generated by lowering the SDA signal while the SCL signal is high.
- Master device sends slave address (7-bit) and the data direction bit (R/W = 0).
- Slave device sends acknowledge signal if the slave address is correct.
- Master sends control register address (8-bit)
- Slave sends acknowledge signal
- Master sends data byte to be written to the addressed register
- Slave sends acknowledge signal
- If master will send further data bytes the control register address will be incremented by one after acknowledge signal (repeat step f and g)
- Master generates STOP condition to indicate write cycle end

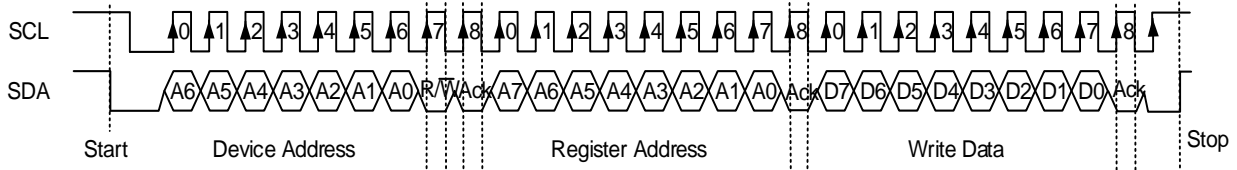
Figure 15. I<sup>2</sup>C Write Byte Cycle

## Read Cycle

In a read cycle, the following steps should be followed:

- Master device generates START condition
- Master device sends slave address (7-bit) and the data direction bit (R/W = 0).
- Slave device sends acknowledge signal if the slave address is correct.
- Master sends control register address (8-bit)
- Slave sends acknowledge signal
- Master generates STOP condition followed with START condition or REPEAT START condition
- Master device sends slave address (7-bit) and the data direction bit (R/W = 1).
- Slave device sends acknowledge signal if the slave address is correct.
- Slave sends data byte from addressed register.
- If the master device sends acknowledge signal, the slave device will increase the control register address by one, then send the next data from the new addressed register.
- If the master device generates STOP condition, the read cycle is ended.

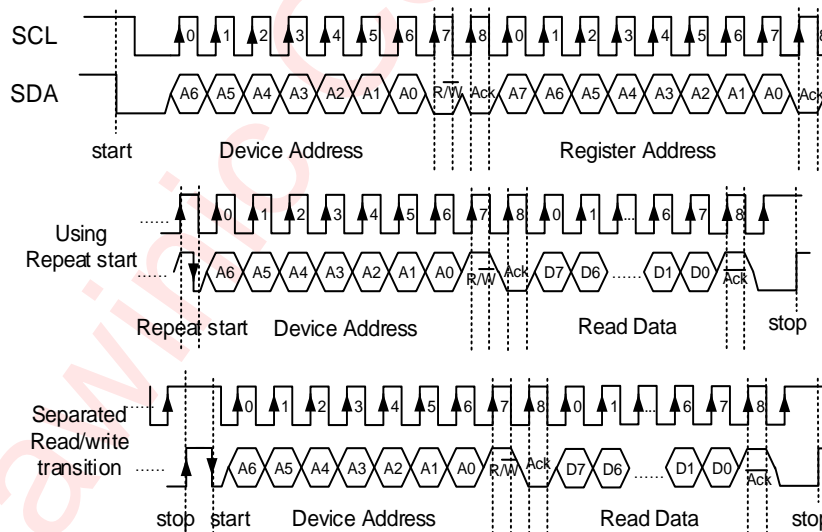
Figure 16. I<sup>2</sup>C Read Byte Cycle

Register Configuration<sup>(NOTE7)</sup>

ADDR	NAME	R/W	Bit7	Bit6	Bit5	Bit4	Bit3	Bit2	Bit1	Bit0	Default
0x00	ID	R	CHIP_ID								0x03
0x01	SFTRST	R/W	R							RESET	0x00
0x02	MODE	R/W	R			PDIS	R	MAP	WORKMODE		0x00
0x03	LEDCUR	R/W	BL_FS					CH3EN	CH2EN	CH1EN	0x9F
0x04	BSTCTR1	R/W	SF_SFT		SF	OVPSSEL		OCPSEL			0x2E
0x05	BSTCTR2	R/W	AFEN	INDSEL	EMISEL						0x00
0x06	LEDLSB	R/W	R					LSB			0x07
0x07	LEDMBSB	R/W	MSB								0xFF
0x08	PWM	R/W	P_SF		P_ACT	P_HYS			P_FLT		0x93
0x09	TURNCFG	R/W	ON_TIM				OFF_TIM				0x44
0x0A	TRANCFG	R/W	R	PWM_TIM			IIC_TIM			0x00	
0x0B	FLASH	R/W	FLTO_TIM				FL_S				0x58
0x0C	AFHIGH	R/W	AF_HIGH								0x80
0x0D	AFLOW	R/W	AF_LOW								0x10
0x0E	FLAGS1	R	CH1 OPEN	CH2 OPEN	CH3 OPEN	CH1 SHORT	CH2 SHORT	CH3 SHORT	OCP	OT	0x00
0x0F	FLAGS2	R	OVP	UVLO	FLTO	R					0x00

NOTE7: The default value refers to the set value of the registers when the chip is manufactured, which is the recommendation setting to maintain the overall function and good performance of the chip as well.

## Register Detailed Description

## ID : CHIP ID Register (Address 00H)

Bit	Symbol	R/W	Description	Default
7:0	CHIP_ID	R	CHIP ID	0x03

## SFTRST : Soft Reset Register (Address 01H)

Bit	Symbol	R/W	Description	Default
7:1	-	R	Reserved	0x00
0	RESET	R/W	Soft reset 0: Don't reset (default) 1: Reset (automatically back to 0)	

## MODE : Mode Register (Address 02H)

Bit	Symbol	R/W	Description	Default
7:5	-	R	Reserved	0x00
4	PDIS	R/W	PWM dimming disable 0: PWM dimming enable (default) 1: PWM dimming disable	
3	-	R	Reserved	
2	MAP	R/W	Map type	

			0: exponential (default) 1: linear	
1:0	WORKMODE	R/W	Work mode 00: standby (default) 01: backlight 1x: flash	

**LEDCUR : LED Current Register (Address 03H)**

Bit	Symbol	R/W	Description	Default
7:3	BL_FS	R/W	Backlight full scale current IFS = 4.8mA + code × 0.8mA 00000 = 4.8mA 00001 = 5.6mA ..... 10011 = 20mA (default) ..... 11111 = 29.6mA	0x9F
2	CH3EN	R/W	CH3 enable 0: disable 1: enable (default)	
1	CH2EN	R/W	CH2 enable 0: disable 1: enable (default)	
0	CH1EN	R/W	CH1 enable 0: disable 1: enable (default)	

**BSTCTR1 : Boost Control1 Register (Address 04H)**

Bit	Symbol	R/W	Description	Default
7:6	SF_SFT	R/W	Switching frequency shift 00: No Shift (default) 01: Shift Up by 17% 10: Shift Down by 11% 11: Shift Down by 19%	0x2E
5	SF	R/W	Switching frequency 0: 500kHz 1: 1000kHz (default)	
4:2	OVPSEL	R/W	Over voltage protect select 000: 17.5V 001: 24V 010: 31V 011: 38V (default) 1xx: 41.5V	
1:0	OCPSEL	R/W	Over current protect select 00: 0.9A	

Bit	Symbol	R/W	Description	Default
			01: 1.8A 10: 2.7A (default) 11: 3.4A	

**BSTCTR1 : Boost Control2 Register (Address 05H)**

Bit	Symbol	R/W	Description	Default
7	AFEN	R/W	Auto frequency enable 0: disable (default) 1: enable	0x00
6	INDSEL	R/W	Inductor select 0: 4.7 $\mu$ H (default) 1: 10 $\mu$ H	
5:3	EMISEL	R/W	EMI Select 000: typical (default) 001: slow3 010: slow2 011: slow1 100: fast1 101: fast2 110: fast3 111: fast4	
2:0	-	R	Reserved	

**LEDLSB : LED Brightness LSB Register (Address 06H)**

Bit	Symbol	R/W	Description	Default
7:3	-	R/W	Reserved	0x07
2:0	LSB	R/W	LED brightness lower 3bit LSB	

**LEDMSB : LED Brightness MSB Register (Address 07H)**

Bit	Symbol	R/W	Description	Default
7:0	MSB	R/W	LED brightness higher 8bit MSB	0xFF

**PWM : PWM Control Register (Address 08H)**

Bit	Symbol	R/W	Description	Default
7:6	P_SF	R/W	PWM sample rate 00: 800kHz 01: 4MHz 1x: 24MHz (default)	0x93
5	P_ACT	R/W	PWM active 0: high active (default) 1: low active	
4:2	P_HYS	R/W	PWM hysteresis 000: none 001: 1 LSB	

Bit	Symbol	R/W	Description	Default
			010: 2 LSBs 011: 3 LSBs 100: 4 LSBs (default) 101: 5 LSBs 110: 6 LSBs 111: 7 LSBs	
1:0	P_FLT	R/W	PWM filter 00: no filter 01: 100ns 10: 150ns 11: 200ns (default)	

**TURNSET : Turn ON/OFF Ramp Time Register (Address 09H)**

Bit	Symbol	R/W	Description	Default
7:4	ON_TIM	R/W	Turn on ramp time 0000: 512μs 0001: 1ms 0010: 2ms 0011: 4ms 0100: 8ms (default) 0101: 16ms 0110: 32ms 0111: 64ms 1000: 128ms 1001: 256ms 1010: 512ms 1011: 1024ms 1100: 2048ms 1101: 4096ms 1110: 8192ms 1111: 16384ms	0x44
3:0	OFF_TIM	R/W	Turn off ramp time 0000: 512μs 0001: 1ms 0010: 2ms 0011: 4ms 0100: 8ms (default) 0101: 16ms 0110: 32ms 0111: 64ms 1000: 128ms 1001: 256ms 1010: 512ms 1011: 1024ms 1100: 2048ms 1101: 4096ms	

Bit	Symbol	R/W	Description	Default
			1110: 8192ms 1111: 16384ms	

**TRANSET : Transition Ramp Time Register (Address 0AH)**

Bit	Symbol	R/W	Description	Default
7	-	R	Reserved	0x00
6:4	PWM_TIM	R/W	PWM transition ramp time 000: 2ms (default) 001: 4ms 010: 8ms 011: 16ms 100: 32ms 101: 64ms 110: 128ms 111: 256ms	
3:0	IIC_TIM	R/W	I <sup>2</sup> C transition ramp time 0000: 1μs/step (default) 0001: 128ms 0010: 192ms 0011: 256ms 0100: 320ms 0101: 384ms 0110: 448ms 0111: 512ms 1000: 576ms 1001: 640ms 1010: 768ms 1011: 1024ms 1100: 1280ms 1101: 1536ms 1110: 2560ms 1111: 4096ms	

**FLASH : Flash Setting Register (Address 0BH)**

Bit	Symbol	R/W	Description	Default
7:4	FLTO_TIM	R/W	Flash timeout time 0000: no flash timeout 0001: 100ms 0010: 200ms 0011: 300ms 0100: 400ms 0101: 500ms (default) 0110: 600ms 0111: 700ms 1000: 800ms 1001: 900ms	0x58



Bit	Symbol	R/W	Description	Default
			1010: 1000ms 1011: 1100ms 1100: 1200ms 1101: 1300ms 1110: 1400ms 1111: 1500ms	
3:0	FL_S	R/W	Flash current $I_{FLASH} = (1 + (\text{code} + 2)/10) \times 29.6\text{mA}$ 0000: 35.52mA 0001: 38.48mA ..... 1000: 59.2mA (default) ..... 1110: 76.96mA 1111: 79.92mA	

**AFHIGH : Auto Frequency High Threshold Register (Address 0CH)**

Bit	Symbol	R/W	Description	Default
7:0	AF_HIGH	R/W	Auto frequency high threshold value	0x80

**AFLOW : Auto Frequency Low Threshold Register (Address 0DH)**

Bit	Symbol	R/W	Description	Default
7:0	AF_LOW	R/W	Auto frequency low threshold value	0x10

**FLAG1 : FLAGS1 Register (Address 0EH)**

Bit	Symbol	R/W	Description	Default
7	LED1OPEN	R/W	Channel 1 open flag	0x00
6	LED2OPEN	R/W	Channel 2 open flag	
5	LED3OPEN	R/W	Channel 3 open flag	
4	LED1SHORT	R/W	Channel 1 short flag	
3	LED2SHORT	R/W	Channel 2 short flag	
2	LED3SHORT	R/W	Channel 3 short flag	
1	OCP	R/W	Over current protection flag	
0	OT	R/W	Over temperature protection flag	

**FLAG2 : FLAGS2 Register (Address 0FH)**

Bit	Symbol	R/W	Description	Default
7	OVP	R/W	Over voltage protection flag	0x00
6	UVLO	R/W	UVLO flag	
5	FL_TO	R/W	Flash timeout flag	
4:0	-	R	Reserved	

## Application Information

### Inductor Selection Guideline

Because the selection of inductor affects power supply's steady state operation, transient behavior, loop stability and the boost converter efficiency, the inductor is one of the most important components in switching power regulator design. There are three important inductor specifications, inductor value, DC resistance and saturation current.

The inductor DC current can be calculated as:

$$I_{IN\_DC} = \frac{V_{OUT} \times I_{out}}{V_{IN} \times \eta} \quad (3)$$

The inductor current peak to peak ripple can be calculated as

$$I_{PP} = \frac{1}{L \times F_s \times \left( \frac{1}{V_{OUT} + V_F - V_{IN}} + \frac{1}{V_{IN}} \right)} \quad (4)$$

Therefore, the peak current  $I_P$  seen by the inductor is calculated as

$$I_P = I_{IN\_DC} + \frac{I_{PP}}{2} \quad (5)$$

The inductor saturation current rating should be considered to cover the inductor peak current. Smaller size and better efficiency are the major concerns for portable devices. The inductor should have low core loss and low DCR for better efficiency. For these reasons, a 4.7 $\mu$ H to 10 $\mu$ H inductor value range is recommended for backlight mode. A 10 $\mu$ H inductor optimized the efficiency for most application while maintaining low inductor peak to peak ripple. **Table 7** lists the recommended inductor for the AW99703. When recommending inductor value, the factory has considered -40% and +20% tolerance from its nominal value.

**Table 7. Recommended Inductors for AW99703 at backlight mode**

Part Number	L ( $\mu$ H)	DCR Max ( $\Omega$ )	Saturation Current (mA)	Size (L x W x H mm)	Vendor
MRSC252A10-100M-N	10	0.5	900	2.5 x 2 x 1	Chilisin
LQH3NPN100NM0	10	0.3	750	3 x 3 x 1.5	Murata
CDH3809/SLD	10	0.3	570	4 x 4 x 1.0	Sumida
LPS4018-472ML	4.7	0.125	1900	4 x 4 x 1.8	Coilcraft

### Schottky Diode Selection

To optimize the efficiency, a high-speed and low reverse-recovery current Schottky diode are recommended. Make sure the diode's average and peak current ratings exceed the output average LED current and the peak inductor current. In addition, the diode's break-down voltage rating must exceed the maximum voltage across the diode. Usually, unexpected high-frequency voltage spikes can be seen across the diode when the diode turns off. Therefore, leaving some voltage rating margin is always needed to guarantee normal long-term operation when selecting a diode. The MBR0540 and the NSR05F40 are recommended for AW99703.

## Input and Output Capacitors Selection

The output capacitor keeps the output voltage ripple small and ensures feedback loop stability. This ripple voltage is related to the capacitor's capacitance and its equivalent series resistance (ESR). Assuming ESR of a capacitor is zero, the minimum capacitance needed for a given ripple can be calculated by:

$$C_{OUT} = \frac{(V_{OUT} - V_{IN}) \times I_{out}}{V_{OUT} \times F_S \times V_{ripple}} \quad (6)$$

Where,  $V_{ripple}$  represents peak-to-peak output ripple. The additional output ripple caused by ESR can be calculated as:

$$V_{ripple\_ESR} = I_{out} \times R_{ESR} \quad (7)$$

$V_{ripple\_ESR}$  can be neglected for ceramic capacitors due to its low ESR, but must be considered if tantalum or electrolytic capacitors are used.

Note that with a tolerance, temperature and DC voltage shift, the effective capacitance will be much lower than its nominal capacitance. A minimum effective capacitance at the output should be over 0.4 $\mu$ F in the application. The output capacitor affects the loop stability of the boost regulator. If the output capacitor is below the range, the boost regulator can potentially become unstable. Therefore, leave enough margin on the voltage rating to ensure adequate capacitance at the required output voltage. [Table 8](#) lists the recommended output capacitors for the AW99703.

An X5R or X7R capacitor of 10 $\mu$ F is recommended for input side. The output requires an X5R or X7R capacitor in the range of 0.47 $\mu$ F to 4.7 $\mu$ F. A 100nF capacitor and a 33 pF capacitor are recommended to use in parallel with the input capacitor and the output capacitor to suppress high frequency noise.

Note that capacitor degradation will increase the ripple dramatically. Select the capacitor with 50V rated voltage to reduce the degradation at the output voltage. If the output ripple is too large, change a capacitor with less degradation effect or with higher rated voltage could be helpful.

**Table 8. Recommended output capacitors for the AW99703**

Part Number	C ( $\mu$ F)	Voltage Rating (V)	Case Size	Tolerance (%)	Temperature Coefficient (%)	Vendor
CGA3E3X5R1H105K080AB	1.0	50	0603	$\pm$ 10	$\pm$ 15	TDK
CGA4J3X7R1H105K125AB	1.0	50	0805	$\pm$ 10	$\pm$ 15	TDK
C2012X5R1H225K085AB	2.2	50	0805	$\pm$ 10	$\pm$ 15	TDK
GRT188R61H105KE13	1.0	50	0603	$\pm$ 10	$\pm$ 15	Murata
GRT21BR71H105KE01	1.0	50	0805	$\pm$ 10	$\pm$ 15	Murata
GRM188R61H225KE11	2.2	50	0603	$\pm$ 10	$\pm$ 15	Murata

For example, with a 10% tolerance, a 15% temperature coefficient and the DC voltage characteristic, the value of capacitance must be  $\geq 0.4 / (0.9 \times 0.85) = 0.523\mu$ F. For configurations where the output voltage is high, the two of these capacitors can be paralleled, or a larger capacitor such as the GRM188R61H225KE11 recommended be used.

## Power Dissipation

The maximum IC junction temperature should not be exceeded 125°C under normal operating conditions. This restriction limits the power dissipation of the AW99703. It is recommended to keep the actual dissipation less than or equal to  $P_{D(max)}$ . The maximum-power-dissipation limit is determined by using the following equation:

$$P_{D(max)} = \frac{T_{Jmax} - T_A}{\theta_{ja}}$$

Where,  $T_{Jmax}$  is the Maximum Junction Temperature,  $T_A$  is the maximum ambient temperature for the application.  $\theta_{ja}$  is the thermal resistance junction-to-ambient given in Power Dissipation Table.

awinic Confidential

## PCB Layout Consideration

### Layout Guidelines

PCB layout is an important design step for those high frequency, high current switching power regulators in order to minimize noise and keep loop stable. To reduce switching losses, it is better to make the SW pin rise and fall times as short as possible. Minimizing the length and area of all traces connected to the SW pin and using a ground plane under the switching regulator are strongly recommended to minimize inter-plane coupling. The input capacitor should be very close to the IC to get the best decoupling. The path of the inductor, schottky diode and output capacitor should be kept as short as possible to minimize noise and ringing. HVLED1, HVLED2, HVLED3 are sensitive nodes and they should be kept separate from the SW pin in the PCB layout.

The input and the output bypass capacitors should be placed as close to the IC as possible. Minimize trace lengths between the IC and the inductor, the diode and the output capacitor; keep these traces short, direct, and wide.

### Layout Example

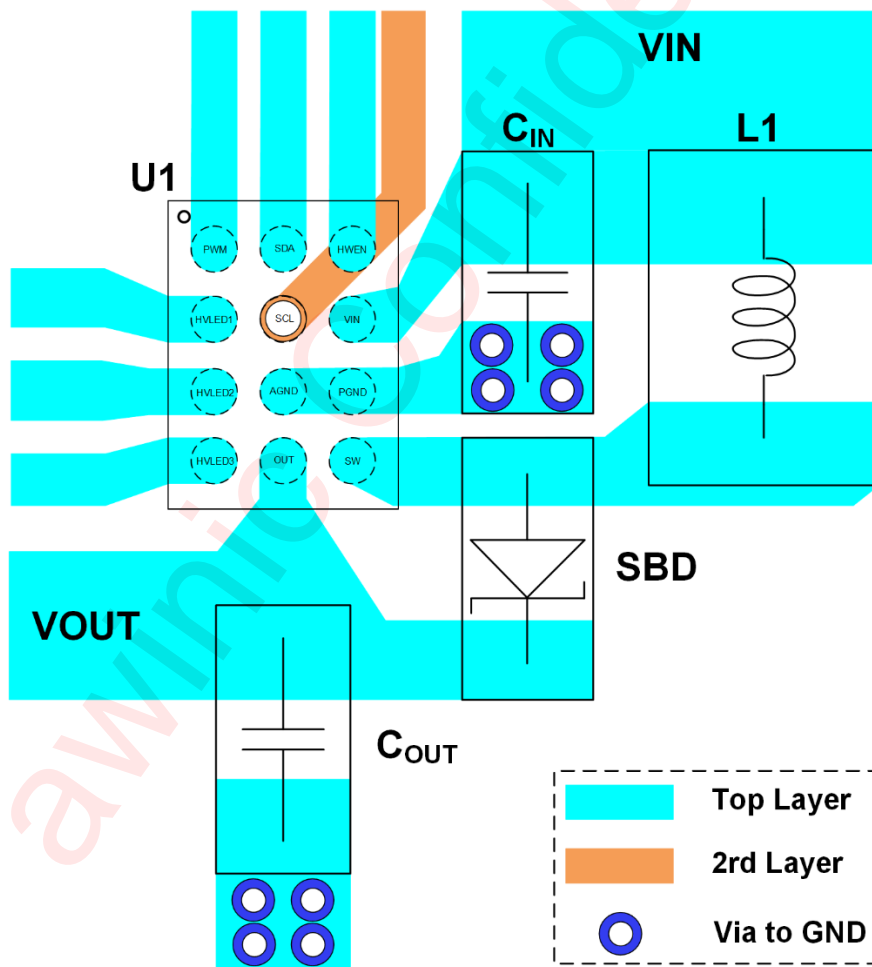
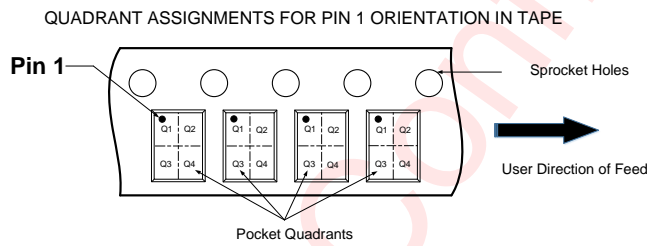
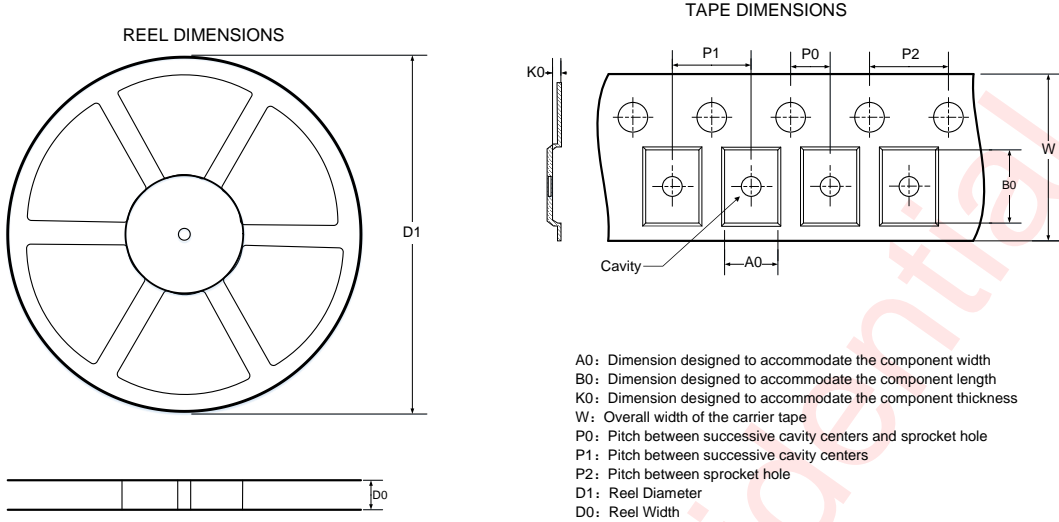

Figure 17. AW99703 Layout Example

## Tape And Reel Information



DIMENSIONS AND PIN 1 ORIENTATION

D1 (mm)	D0 (mm)	A0 (mm)	B0 (mm)	K0 (mm)	P0 (mm)	P1 (mm)	P2 (mm)	W (mm)	Pin1 Quadrant
179.00	9.00	1.35	1.75	0.70	2.00	4.00	4.00	8.00	Q1

All dimensions are nominal

Package Description

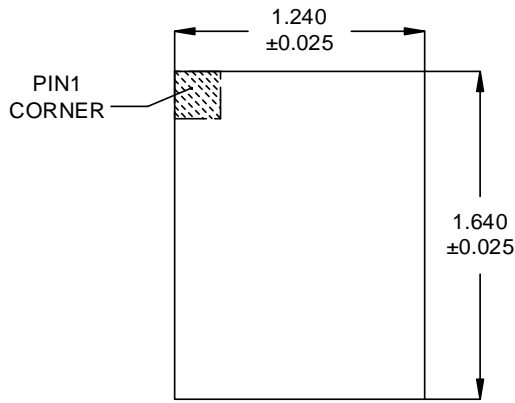

Top View

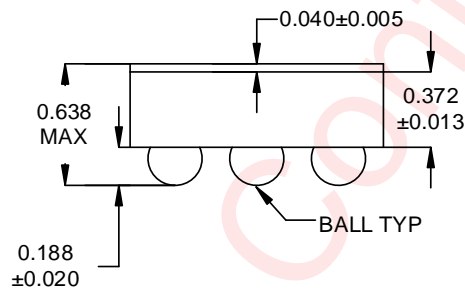

Side View

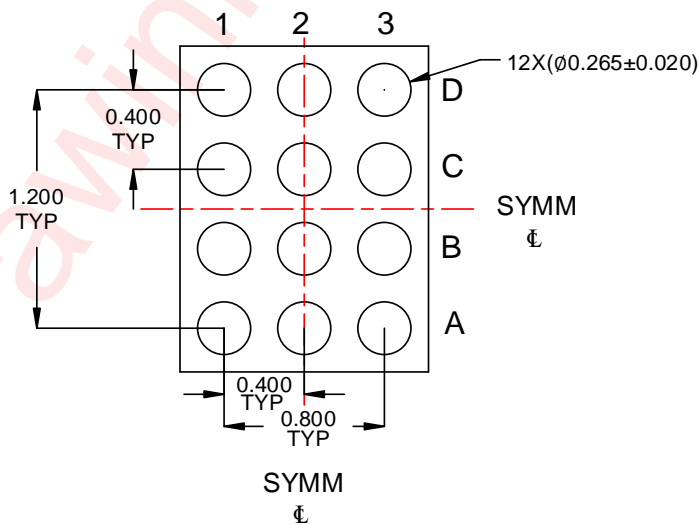

Bottom View

Unit: mm

Land Pattern

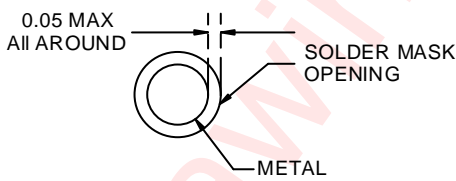
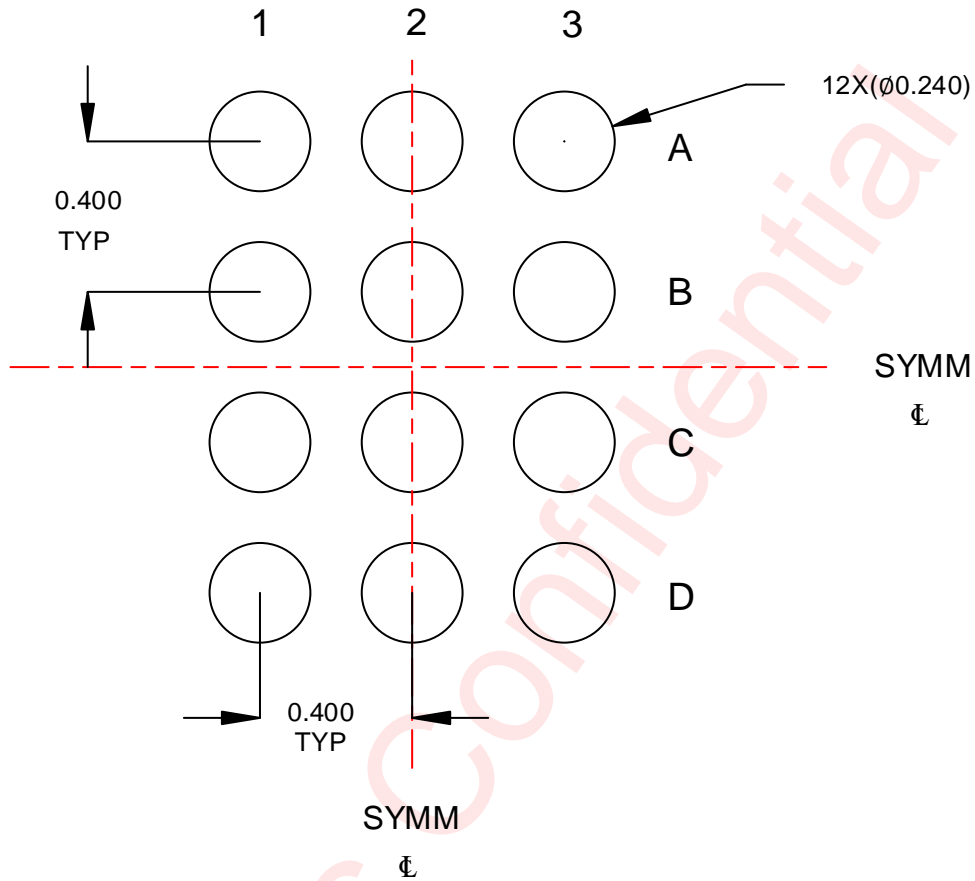

NON-SOLDER MASK DEFINED

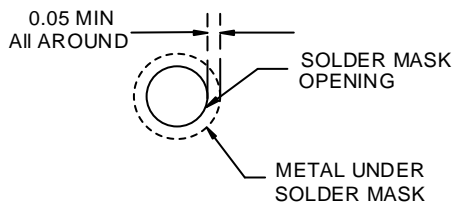

SOLDER MASK DEFINED

Unit: mm



## Reversion History

Version	Date	Change Record
V1.0	Oct. 2018	First official version released
V1.1	Sep. 2019	Update chip performance parameters and increase efficiency laboratory result
V1.2	Dec. 2019	Update the value of $V_{HR}$ in Electrical Characteristics part Update the value of $\theta_{JA}$ in Absolute Maximum Ratings Update the Operation States Update the Input and Output Capacitors Selection Distinguish AGND and PGND of chip pins
V1.3	Aug. 2021	Correct page footer www.awinic.com.cn to www.awinic.com Added EMI programmable steps description
V1.4	Mar. 2023	Update the description of LED open/short protection to detection on page1 and page4
V1.5	Jan. 2024	Update the description of Operation States and add figure Operation Timing of AW99703 Backlight Mode on page15 Update the description of Channel Enable/Disable on page20
V1.6	Mar. 2024	Update the description of PDIS in Mode Register (Address 02H) on page 28

## Disclaimer

All trademarks are the property of their respective owners. Information in this document is believed to be accurate and reliable. However, Shanghai AWINIC Technology Co., Ltd (AWINIC Technology) does not give any representations or warranties, expressed or implied, as to the accuracy or completeness of such information and shall have no liability for the consequences of use of such information.

AWINIC Technology reserves the right to make changes to information published in this document, including without limitation specifications and product descriptions, at any time and without notice. Customers shall obtain the latest relevant information before placing orders and shall verify that such information is current and complete. This document supersedes and replaces all information supplied prior to the publication hereof.

AWINIC Technology products are not designed, authorized or warranted to be suitable for use in medical, military, aircraft, space or life support equipment, nor in applications where failure or malfunction of an AWINIC Technology product can reasonably be expected to result in personal injury, death or severe property or environmental damage. AWINIC Technology accepts no liability for inclusion and/or use of AWINIC Technology products in such equipment or applications and therefore such inclusion and/or use is at the customer's own risk.

Applications that are described herein for any of these products are for illustrative purposes only. AWINIC Technology makes no representation or warranty that such applications will be suitable for the specified use without further testing or modification.

All products are sold subject to the general terms and conditions of commercial sale supplied at the time of order acknowledgement.

Nothing in this document may be interpreted or construed as an offer to sell products that is open for acceptance or the grant, conveyance or implication of any license under any copyrights, patents or other industrial or intellectual property rights.

Reproduction of AWINIC information in AWINIC data books or data sheets is permissible only if reproduction is without alteration and is accompanied by all associated warranties, conditions, limitations, and notices. AWINIC is not responsible or liable for such altered documentation. Information of third parties may be subject to additional restrictions.

Resale of AWINIC components or services with statements different from or beyond the parameters stated by AWINIC for that component or service voids all express and any implied warranties for the associated AWINIC component or service and is an unfair and deceptive business practice. AWINIC is not responsible or liable for any such statements.